

Constructing Motivation for Sports Activities among College Students using CB-SEM Path Model

Bahtiar Jamili Zaini¹, Zahayu Md Yusof², Rosnalini Mansor³, Norzairiah Zainuddin⁴, Nurul
Faziera Khairul Adlee⁵ and Hanun Nasuha Lop Ahmad⁶

^{1,2,3,4,5,6}School of Quantitative Sciences, Universiti Utara Malaysia, 06010 UUM Sintok, Kedah,
Malaysia.

1bahtiar@uum.edu.my, 2zahayu@uum.edu.my, 3rosnalini@uum.edu.my,
4norzairiah@mara.gov.my, 5nurulfaziera18@yahoo.com, 6hanunnasuhhalopahmad@yahoo.com

Abstract: *Sports is a physical activity that allows members to encounter enjoyment and competition, while simultaneously gaining positive results. This study proposed to investigate the factors affecting students' motivation in sports activities, hence identifying the relationship between these factors and to develop a conceptual model to help in explaining students' motivation towards sports activities. A quantitative research design was chosen, and the respondents were (N=204) College Students in Universiti Utara Malaysia. The responses towards the questionnaire will be illustrated in semantic scale between 1 and 7. Structural equation modelling was used to model the self-administered research questions. The results demonstrated that all factors have direct influence towards students' motivation in sports activities and that self-appearance is the highest factor that contributes to students' motivation towards sports activities. This study can also be used to help students to raise their motivations towards sports activities.*

Keywords: *students' motivation, sports motivation, structural equation modelling, factor analysis*

1. Introduction

Sports are identified as the most popular activities for youth participation, especially college students and have many social and economic implications in a society (Miragaia & Soares, 2017). Most young college students are experiencing periods of physical, social, mental, and fundamental change, which can affect the limitations and inspiration of physical movement (Diehl & Hilger, 2015). College students communicate in specific groups and are influenced by changes in additional living conditions with the start of their university journey.

Students' daily lives are characterised by inactive behaviours, such as attending classes or completing assignments. However, physical movement in this age is very important, given the fact that future well-being examples have been compiled as they are now at this phase of life (Sawyer et al., 2012). Therefore, students' activities other than attending lessons also involve physical activities, such as sports. Moreover, obesity problems occur due to the lack

of physical activity in this age that can provide antagonistic health outcomes in the future(Reilly & Kelly, 2011).

Various concepts of sports motivation have been used to gain a better understanding of college students' behaviour to perform sports activities. Specifically, there are many motivational factors for college students to involve in sports activities consisting of fun, leisure, improving performance or skills, challenges, to seek new sensations, meeting new friends, success, winning, and health(Berki, Piko, & Page, 2020; Kondrič, Sindik, Furjan-Mandić, & Schiefler, 2013; Memon, Ali, Attiq Ur Rehman Memon, & Feroz, 2018; Vallerand & Losier, 1999). College students who play sports are easier to make friends with and they are more satisfied with their appearance, as well as reducing the stress they faced. Thus, sports activities are opportunities to enhance social relationships and to feel that they are a part of a group (Allen, 2003; Fenyves, Dajnoki, Kerezsi, & Bába, 2019; Lawler, Heary, & Nixon, 2020).The presence of a group, in view of athletes, can be a source of social relationships that meet the basic needs of group members(Blynova, Kruglov, Semenov, Los, & Popovych, 2020). The concept of a game accompanied by rewards, health, status, or performance affects the involvement of students in sports (Kucukibis & Gul, 2019). Motivation is important in sports so that continuity is maintained and can improve the achievement for athletes in sports. It can influence a person to engage in sports activities. Motivation is basically a mental state that drives action and gives strength to meet needs, giving satisfaction, or reducing imbalances (Fitri & Dewi, 2020). Motivation greatly affects the performance of an athlete in situations where a person is physically able to perform a task better despite feeling his inability at first (Kondrič et al., 2013).

Abundant studies have been conducted to see the motives of students participating in sports activities. Motivation for interest in sports is often measured by asking about its advantages, what benefits are gained, and how the sports activities are carried out. Among the factors that contribute significantly on motivation in sports activities include self-appearance factors, personal inspiration, fitness, and interpersonal relationships(Allen, 2003; Diehl, Fuchs, Rathmann, & Hilger-Kolb, 2018; Fenyves et al., 2019; Fitri & Dewi, 2020; Kondrič et al., 2013; Lawler et al., 2020). Self-appearance factors are more towards the formation of body image that includes thoughts about body shape, desire to slim down, and feelings of physical well-being after playing sports(Diehl et al., 2018). Body weight also seems to be important to college students. Personal inspiration is related to life balance factors, reducing anxiety, stress, and anxiety in relationships with others. Sports can also divert attention from the problems encountered. Sports can also improve self-perception, where participants tend to be satisfied with their appearance, tend to be less stressed, more future-oriented, and more inclined to self-regulated behaviour (Fenyves et al., 2019).Athletes who are highly committed feel a higher level of enjoyment, opportunity, achievement, and social support (Berki et al., 2020). Fitness factors include striving to maintain fitness levels, being healthy, improving performance, and feeling healthy (Diehl et al., 2018). Interpersonal relationships, on the other hand, refer to opportunity for significant interpersonal interactions, friendship opportunities, social recognition, and the development of social bonds with others (Allen, 2003; Lawler et al., 2020).Relationships among team members can also be a source of motivation to increase social support, social comparison, and teamwork (Evans, Eys, & Wolf, 2013). Therefore, with a lot of psychological support from sports activities, they encourage a person to get involved in sports.

Participation in sports among students has become a major programme among developed and developing countries. According to Malaysia's national education philosophy, education in Malaysia is structured to balance and integrate individuals who are intellectually, spiritually, emotionally, and physically balanced and harmonious. All students are encouraged to participate in sports activities. The Ministry of Education of Malaysia also introduces Sports Day so that individuals can take part actively in sports activities. Besides that, during primary and secondary school, the schools arrange their own sports day, so that at least each student gets to participate in sports activities. However, during tertiary education, students are exposed to various types of sports activities, but their engagement in sports is powerfully attracted by their motivations. Many students only involved in the sports events as spectator or participant due to some intrinsic or extrinsic factors. In response to this issue, our study proposed to investigate the factors that affect the student's motivation in sports activities, hence identifying the relationship between these factors. These factors are believed to help maintain behaviour and individuals' initiative. Self-appearance factors, personal inspiration, fitness, and interpersonal relationships have also been proven to have influence on motivation in sports activities. A conceptual model was developed to help in explaining students' motivation towards sports activities.

2. Methodology

2.1 Data Collection

This study is based on the self-administered questionnaire related to the student's motivations for sports activities. The primary data for this research is collected from questionnaire. The sample consists of respondents from college students in Universiti Utara Malaysia. The questionnaire, consisting of 37 questions to signify students' motivation for sports activities along with their demographics, was distributed to 204 ($N=204$) College Students in Universiti Utara Malaysia.

2.2 Questionnaire Development:

Data is collected through a paper questionnaire distributed using the online Google Form. The questionnaire consists of questions to signify the students' motivation for sports activities along with their demographics. The questionnaire is developed based on (Diehl et al., 2018). The responses towards questionnaire will be illustrated in semantic scale between 1 (strongly disagree) and 7 (strongly agree). A preliminary questionnaire is also designed to obtain sufficient information to draw conclusions about the students' motivation for sports activities. The effectiveness of the preliminary questionnaire and its strength is tested in an earlier pilot study.

2.3 Method of Data Analysis:

Data collected will be coded for the purpose of analysis. This study will emphasise on primary data by using structured equation modelling (SEM) to determine factors that describe the students' top motivation for sports activities and to develop a new model for students' motivation for sports activities.

2.3.1 Structural Equation Modelling

Structural Equation Modelling (is a particular technique used for statistical modelling in behavioural science, which can be regarded as a mixture of factor, regression or path analysis. The SEM is often concerned with theoretical constructions shown by latent variables. The theory connections are demonstrated by regression or by the factor path coefficient. The structural equation model implies a system of covariance between the factors

that can be observed and offers alternative modelling of the covariance structure of the title. Nevertheless, the model can be expanded to include within the model the means of the variables or factors observed. Factor analysis was carried out first, followed by goodness of fits.

In terms of the quantitative method, this research used factor analysis to obtain variables in either observed or latent forms. Principle component analysis, a factor analysis component is capable of organising information through data reduction and summary characteristics. Interesting characteristics that can be captured include the identification of fundamental aspects (factors), the explanation of correlation between set of variables and the identification of fresh set of uncorrelated variables. Such features will greatly enhance our ability to group variables of comparable characteristics.

2.3.2 Exploratory Factor Analysis (EFA)

This study is conducted to explore the factors that affect students' motivations towards sportsactivities by using Exploratory Factor Analysis (EFA). EFA is a technique for variable reduction that identifies the number of factor constructs and the factor structure underlying the set of variables. Kaiser-Meyer-Olkin (KMO) Measure of Sampling Adequacy was conducted prior to conducting the exploratory factor analysis, where the sample must be more than 0.6 in order to be sufficient (Kaiser, 1974). The outcome demonstrated sufficient proof that our matrix of correlations is not an identity matrix;thereforewe can proceed with exploratory factor analysis.

Factor analysis was carried out using SPSS and SAS statistics instruments based on our questionnaires and represented by a scree plot. The technique of varimax can extract the appropriate variables. The statistical method was used to model extensive multivariable interactions between observed and latent variables, enabling the examination of causal relationships among factors. Figure 1 is the initial conceptual model used in this study.

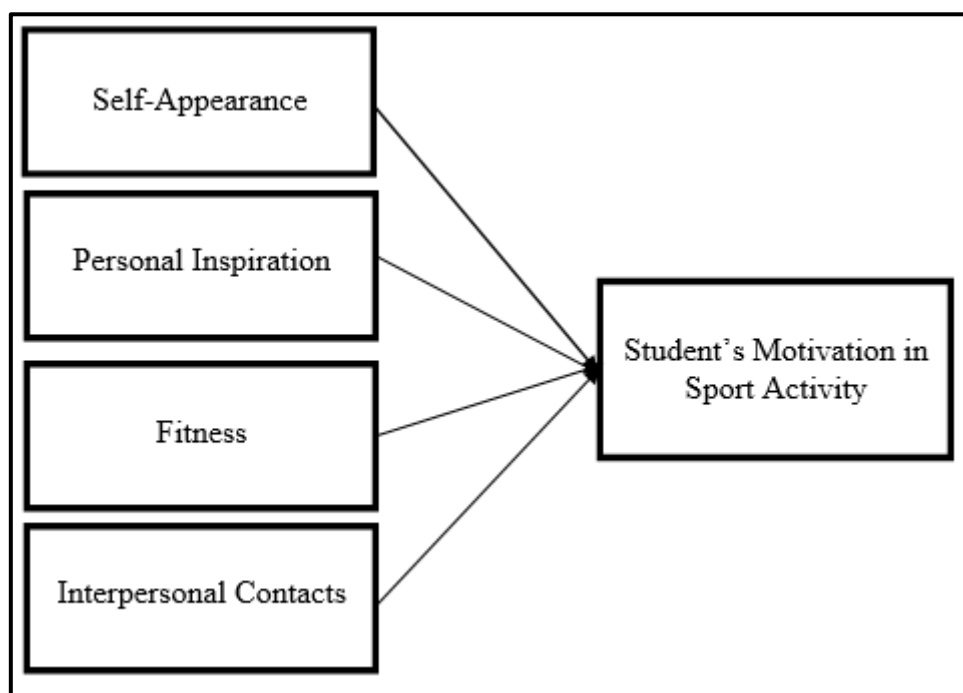

Figure 1:Initial Conceptual Model

2.3.3 Confirmatory Factor Analysis (CFA)

Confirmatory factor analysis (CFA) was used to test the reliability of a measurement model. The AMOS software is used to perform CFA for all measurement elements retained by EFA. Any item with a load factor less than 0.6 will be deleted to achieve uniformity. The extraction should be carried out one at a time by removing the smallest factor first. The model is then re-specified and resumed until no product has a loading factor of less than 0.6. The model's fitness indexes are then acquired to determine the fitness of the model's information. If the fitness index is not fulfilled, it will check the modifying indices (MI). An MI over 15 indicates the correlated error between items. To fix the correlated errors, remove the item or use a double-headed arrow to set the redundant items to 'estimate free parameter'.

Standard chi squares (Chi-square / df), fitness index goodness (GFI), fitness adjusted (AGFI), fitness comparative index (CFI), and root mean error square approximation (RMSEA) were evaluated according to the individual measuring models. The threshold values for all these fit indices were examined when evaluating the measuring model until each individual measuring model meets the acceptance level for each index, showing that each measuring model fits correctly.

Table 1: Criteria of SEM Path Structure (Awang, 2012)

Criteria	Characteristics
Indices	Probability Chi-Square ≥ 0.05
	RMSEA ≤ 0.80
	GFI ≥ 0.90
	AGFI ≥ 0.90
	CFI ≥ 0.90
	NFI ≥ 0.90
	TLI ≥ 0.90
	CMIN/DF ≤ 5

2.3.4 Hypothesis Development

The previous section presents the endogenous constructs derived from the theory of sports motivation. Therefore, this section highlights the hypothesis development from the overview model.

The hypotheses are:

- H1: Self-appearance has direct influence towards student's motivation in sportsactivities.
- H2: Personal inspiration has direct influence towards students' motivation in sportsactivities.
- H3: Fitness has direct influence towards students' motivation in sportsactivities.
- H4: Interpersonal contacts have direct influence towards students' motivation in sportsactivities.

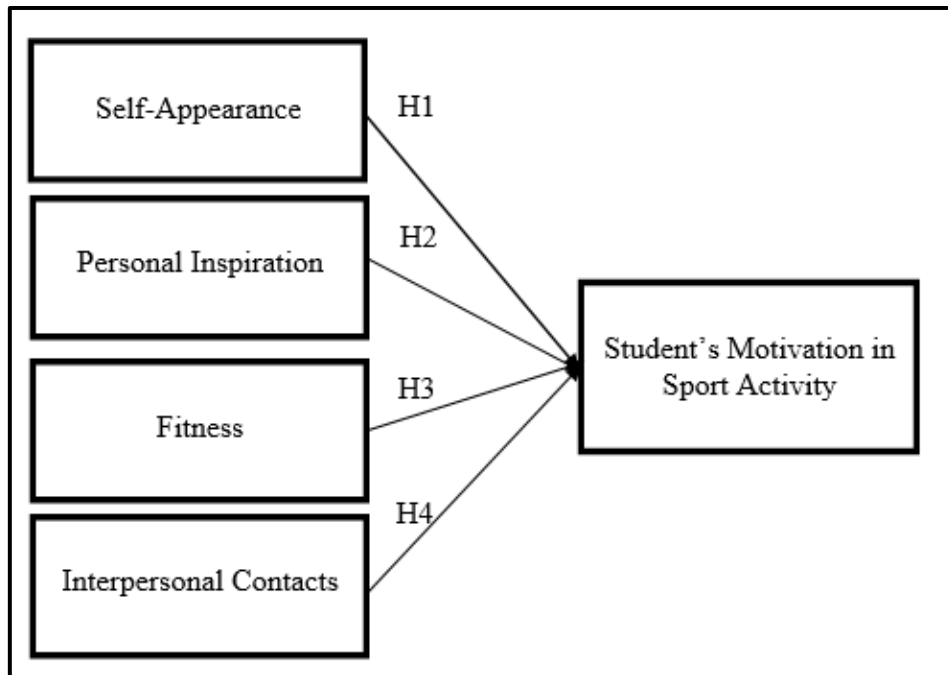

Figure 2: Conceptual Model with hypotheses

3. Analysis and Results

3.1 Exploratory Factor Analysis

The Kaiser's Measure of Sampling Adequacy is used to measure sampling adequacy. Table 2 revealed that the sampling for this study is acceptable with 0.922. If the results are greater than 0.6, then they are considered good enough in KMO (Kaiser, 1974). Therefore, all the variables have relationship with each other. The Factor Analysis is considered as it should be in this study.

Table 2: Kaiser's Measure of Sampling Adequacy and Bartlett's Test

Kaiser-Meyer-Olkin Measure of Sampling Adequacy.		.922
	Approx. Chi-Square	3141.829
Bartlett's Test of Sphericity	df	253
	Sig.	.000

Eigenvalue reflects the number of extracted factors, where the sum should be equal to the number of items subjected to factor analysis. The Eigenvalue table is divided into 3 parts, which are Initial Eigenvalues, Extracted Sums of Squared Loadings, and Rotation of Sums of Squared Loadings. Based on Table 3, it has been reduced due to underlying factors. The 4 components are explained by 66.97 % of the information in all 23 variables. The first component explains more of the variance than other variables.

Table 3: Total Variance Explained

Component	Initial Eigenvalues			Extraction Sums of Squared Loadings			Rotation Sums of Squared Loadings		
	Total	% of Variance	Cumulative %	Total	% of Variance	Cumulative %	Total	% of Variance	Cumulative %
1	10.05	43.694	43.694	10.00	43.694	43.694	4.47	19.466	19.466
2	2.448	10.645	54.340	2.448	10.645	54.340	4.29	18.517	37.982
3	1.747	7.594	61.934	1.747	7.594	61.934	3.43	14.970	52.952
4	1.159	5.039	66.973	1.159	5.039	66.973	3.25	14.021	66.973

Extraction Method: Principal Component Analysis.

Then, 4 factors were considered after optimising the factor structure. The inspection of both eigenvalues and scree plot after factoring supports the conclusion that the 23 variables are reduced to 4 factors in the study. Based on Table 4, 4 factors are highlighted.

Table 4: Number of Item

Factor	Item
Factor 1	S1, S2, S3, S4, S5, S6, S7
Factor 2	PI1, PI3, PI4, PI5, PI6, PI8, PI9
Factor 3	F1, F2, F3, F4, P5
Factor 4	IC1, IC2, IC3, IC4

3.2 Confirmatory Factor Analysis

SEM is a technique often used in many research areas. Nevertheless, there is one big issue concerning this technique. The question is: how does the model represent the best to reflect the data set? Therefore, goodness of fit is introduced to find the model fit. In this study, several numbers of indices are chosen to produce the model fit.

3.2.1 Self-Appearence

The self-appearance model is developed after modification indices were performed as shown in Figure 4. This model initially consists of 7 items, but after MI was performed, only 6 items remained. The chosen indices for Absolute Index are probability of chi-square, GFI, and RMSEA, while for Incremental Index are TLI, CFI and NFI, and CMIN/DF for Parsimony Index. Based on Table 5 below, all indices for Absolute Index already fulfilled the requirement after MI was performed. In addition, the cut off value for Incremental Index needs to be more than 0.9. Thus, the values of TLI (0.981), CFI (0.990), and NFI (0.979) are acceptable. Table 5 also shows the value for Parsimony Index, which consists of CMIN/DF. For CMIN/DF, the cut off value must be less than 5, thus the CMIN/DF after modification with a value of 1.937 is accepted. This model can be used since all indices already fulfilled the requirement.

Table 5: Self-Appearence validity value

	Indices Validity	Before	After
Absolute Index	Chi-Square	96.108	15.497
	Probability	0.000	0.050
	DF	14	8
	GFI	0.877	0.975
	RMSEA	0.170	0.068
	TLI	0.847	0.981

Incremental Index	CFI	0.898	0.990
	NFI	0.884	0.979
Parsimony Index	CMIN/DF	6.865	1.937

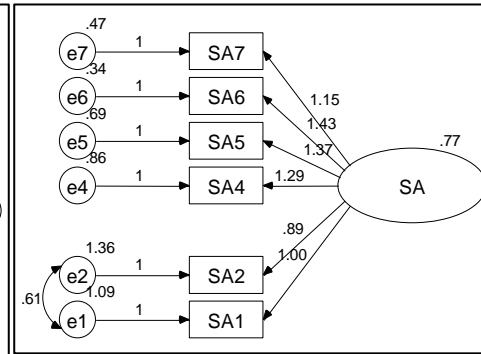
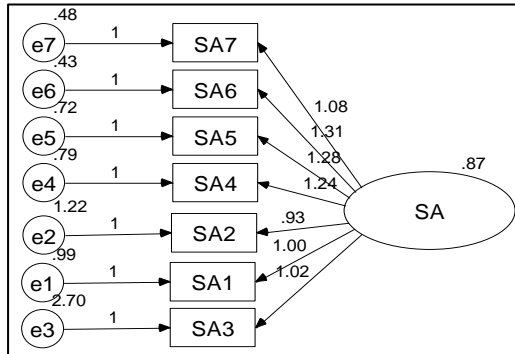

Figure 3: SA before modification

Figure 4: SA after modification

3.2.2 Personal Inspiration

The Personal Inspiration model is developed after modification indices were performed as shown in Figure 6. This model initially consists of 7 items, but after MI was performed, only 6 items remained. The chosen indices for Absolute Index are probability of chi-square, GFI, and RMSEA, while for Incremental Index are TLI, CFI and NFI, and CMIN/DF for Parsimony Index. Based on Table 6 below, all indices for Absolute Index already fulfilled the requirement after MI was performed. In addition, the cut off value for Incremental Index must be more than 0.9. Thus, the values of TLI (0.992), CFI (0.995), and NFI (0.977) are acceptable. Table 6 also shows the value for Parsimony Index, which consists of CMIN/DF. For CMIN/DF, the cut off value must be less than 5, thus the CMIN/DF after modification with a value of 1.257 is accepted. This model can be used since all indices already fulfilled the requirement.

Table 6: Personal Inspiration validity value

	Indices Validity	Before	After
Absolute Index	Chi-Square	25.394	16.339
	Probability	0.031	0.231
	DF	14	13
	GFI	0.966	0.978
	RMSEA	0.063	0.036
Incremental Index	TLI	0.975	0.992
	CFI	0.983	0.995
	NFI	0.964	0.977
Parsimony Index	CMIN/DF	1.814	1.257

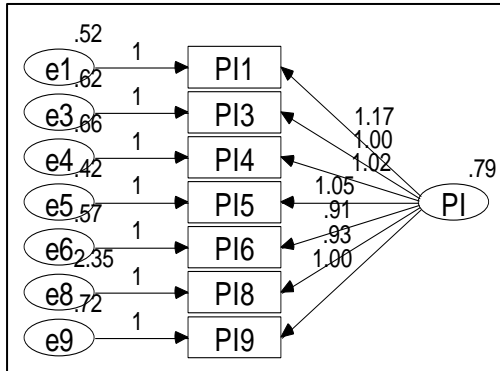

Figure 5: P1 before modification

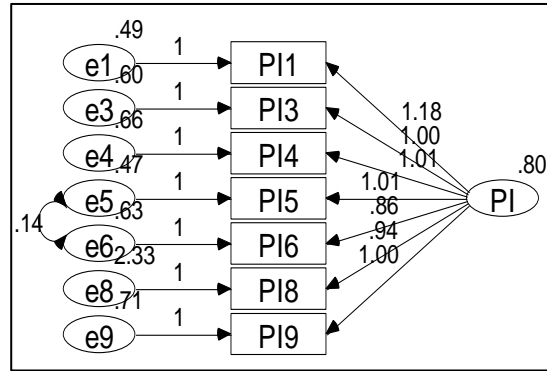

Figure 6: P1 after modification

3.2.3 Fitness

The fitness model is developed after modification indices have been applied as shown in Figure 8. This model consists of 5 items. The chosen indices for Absolute Index are probability of chi-square, GFI, and RMSEA, while for Incremental Index are TLI, CFI and NFI, and CMIN/DF for Parsimony Index. Based on Table 7 below, all indices for Absolute Index already fulfilled the requirement after MI was performed. In addition, the cut off value for Incremental Index must be more than 0.9. Therefore, the values of TLI (0.986), CFI (0.996), and NFI (0.990) are acceptable. Table 7 also shows the value for Parsimony Index, which consists of CMIN/DF. For CMIN/DF, the cut off value must be less than 5, thus the CMIN/DF after modification with a value of 1.746 is accepted. This model can be used since all indices already fulfilled the requirement.

Table 7: Fitness validity value

	Indices Validity	Before	After
Absolute Index	Chi-Square	19.082	5.237
	Probability	0.002	0.155
	DF	5	3
	GFI	0.966	0.990
	RMSEA	0.118	0.061
Incremental Index	TLI	0.975	0.986
	CFI	0.983	0.996
	NFI	0.964	0.990
Parsimony Index	CMIN/DF	1.814	1.746

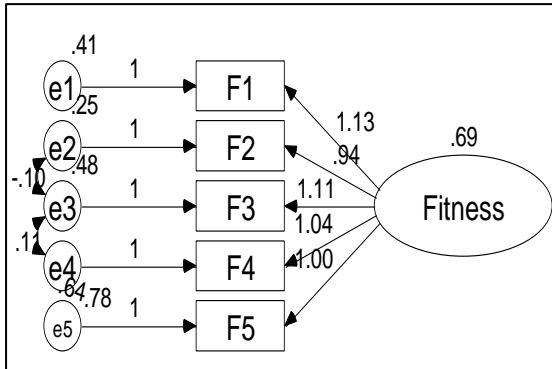
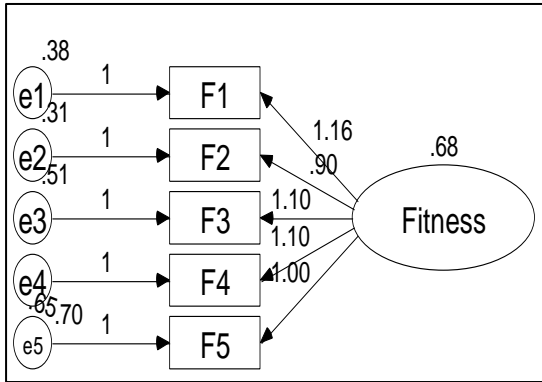

Figure 7: Fitness before modification

Figure 8: Fitness after modification

3.3.4 Interpersonal Contacts

The Interpersonal Contacts model is developed after modification indices have been applied as shown in Figure 10. This model consists of 4 items. The chosen indices for Absolute Index are probability of chi-square, GFI, and RMSEA, while for Incremental Index are TLI, CFI and NFI, and CMIN/DF for Parsimony Index. Based on Table 8 below, all indices for Absolute Index already fulfilled the requirement after MI was performed. In addition, the cut off value for Incremental Index must be more than 0.9. Therefore, the values of TLI (1.008), CFI (1.000), and NFI (0.999) are acceptable. Table 8 also shows the value for Parsimony Index, which consists of CMIN/DF. For CMIN/DF, the cut off value must be less than 5, thus the CMIN/DF after modification with a value of 0.395 is accepted. This model can be used since all indices already fulfilled the requirement.

Table 8: Interpersonal Contacts validity value

	Indices Validity	Before	After
Absolute Index	Chi-Square	8.150	0.395
	Probability	0.017	0.530
	DF	2	1
	GFI	0.980	0.999
	RMSEA	0.123	0.000
Incremental Index	TLI	0.959	1.008
	CFI	0.986	1.000
	NFI	0.982	0.999
Parsimony Index	CMIN/DF	4.075	0.395

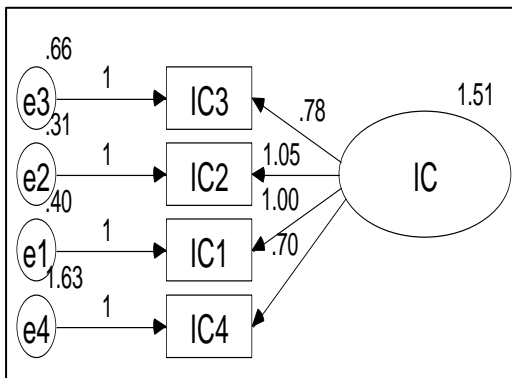

Figure 9: IC before modification

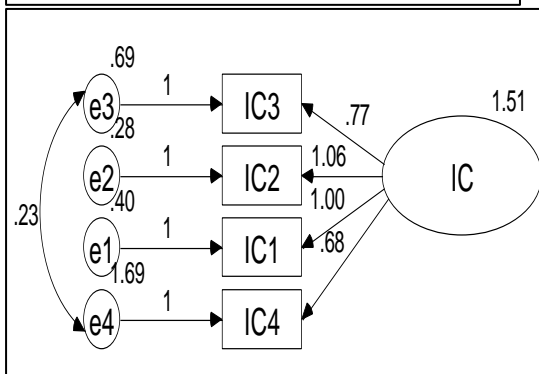

Figure 10: IC after modification

3.3.5 Overall Model Covariance Based Structured Equation Model (CB-SEM)

Finally, the overall model is developed after modification indices have been applied as shown in Figure 12. This model includes all the items. The chosen indices for Absolute Index are probability of chi-square, GFI, AGFI, and RMSEA, while for Incremental Index are TLI, CFI and NFI, and CMIN/DF for Parsimony Index. Based on Table 9 below, all indices for Absolute Index already fulfilled the requirement after MI was performed. In addition, the cut off value for Incremental Index must be more than 0.9 and only the values of TLI (0.930) and CFI (0.944) are acceptable. Table 9 also shows the value for Parsimony Index, which consists of CMIN/DF. For CMIN/DF, the cut off value must be less than 5, thus the CMIN/DF after modification with a value of 1.873 is accepted. Although one index from Incremental Index did not fulfil the requirement (NFI = 0.888), this model can still be used since most indices already fulfilled the requirement.

Table 9: Overall Model validity value

	Indices Validity	Before	After
Absolute Index	Chi-Square	880.806	380.257
	Probability	0.000	0.000
	DF	222	203
	GFI	0.729	0.865
	RMSEA	0.121	0.066
Incremental Index	TLI	0.761	0.930
	CFI	0.790	0.944
	NFI	0.740	0.888

Parsimony Index	CMIN/DF	3.968	1.873
------------------------	----------------	-------	-------

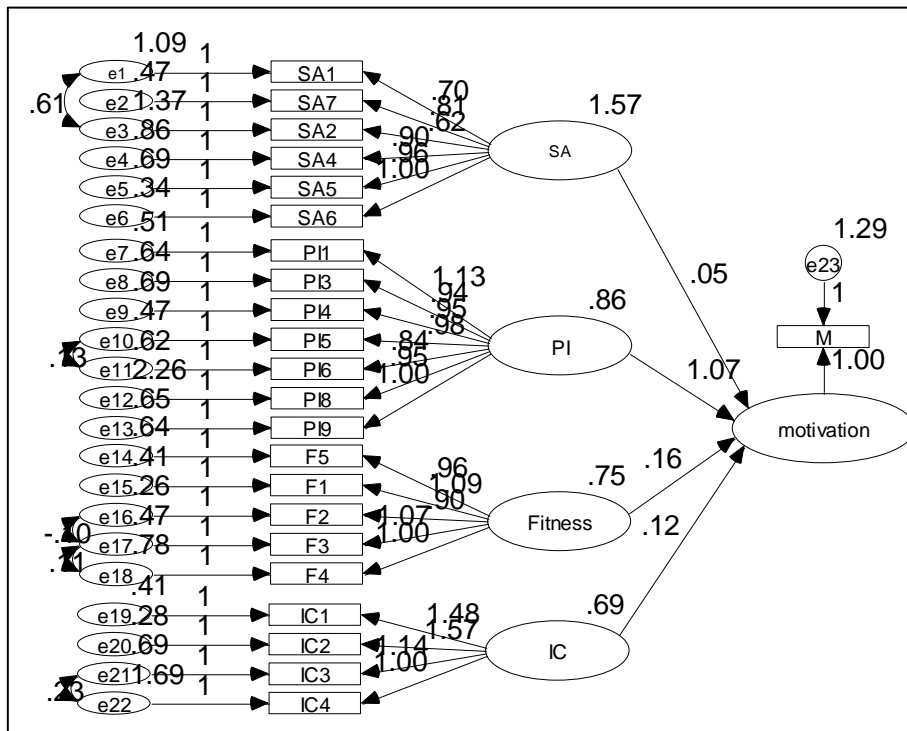

Figure 11: Overall Model before modification

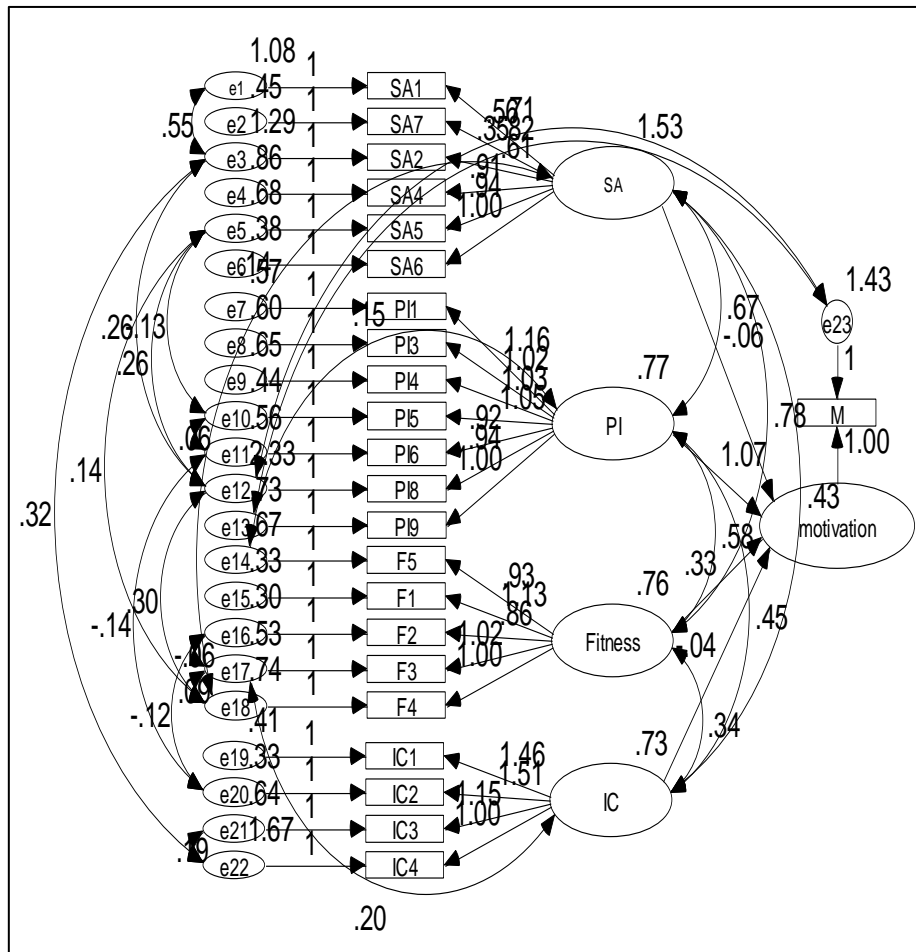

Figure 12: Overall Model after modification

3.3 Hypothesis Testing

The level of significance is often expressed as *p*-value. A significance level of 0.05 is commonly used in academic research rather than 0.01. This study used 0.05 significance level. Based on the acquired results, it is found that there were significant contribution models between the 4 factors, which are self-appearance, personal inspiration, fitness, and interpersonal contacts through students' motivation towards sportsactivities. Table 10 below summarises the results of research hypotheses.

Table 10: Summary of Research Hypothesis Results

Research Hypothesis	p	Results
H1: Self-appearance has direct influence towards students' motivation in sportsactivities.	0.050	Supported
H2: Personal inspiration has direct influence towards students' motivation in sportsactivities.	0.231	Supported
H3: Fitness has direct influence towards students' motivation in sportsactivities.	0.155	Supported
H4: Interpersonal contacts have direct influence towards students' motivation in sportsactivities.	0.530	Supported

4. Conclusion

As a conclusion, this research has determined factors that describe students' motivation for sports activities. It has also developed a new model on student's motivation for sports activities. The study justified that self-appearance, personal inspiration, fitness, and interpersonal contacts are the latent factors towards students' motivation for sports activities. Every factor has correlation with each other. This means that all factors have relationship and are affecting one another. Therefore, these factors will help to raise students' motivation for sports activities. In addition, a model has been developed on students' motivation for sports activities. Based on the results achieved, self-appearance is the highest factor that contributes to students' motivation towards sports activities, followed by personal inspiration, fitness, and interpersonal contacts. It also shows that all factors have direct influence towards students' motivation in sports activities as the significant level for all factors are above 0.05.

Acknowledgement

The authors are grateful for the support received from Universiti Utara Malaysia. They also would like to say thank you to the anonymous reviewers for their useful suggestions.

References:

1. Allen, J. B. (2003). Social motivation in youth sport. *Journal of Sport and Exercise Psychology*, 25(4), 551–567. <https://doi.org/10.1123/jsep.25.4.551>
2. Awang, Z. (2012). *A Handbook on SEM (Structural Equation Modeling), Using AMOS Graphic*. UiTM Press.
3. Berki, T., Piko, B. F., & Page, R. M. (2020). Sport commitment profiles of adolescent athletes: Relation between health and psychological behaviour. *Journal of Physical Education and Sport*, 20(3), 1392–1401. <https://doi.org/10.7752/jpes.2020.03192>
4. Blynova, O., Kruglov, K., Semenov, O., Los, O., & Popovych, I. (2020). Psychological safety of the learning environment in sports school as a factor of achievement motivation development in young athletes. *Journal of Physical Education and Sport*, 20(1), 14–23. <https://doi.org/10.7752/jpes.2020.01002>
5. Diehl, K., Fuchs, A. K., Rathmann, K., & Hilger-Kolb, J. (2018). Students' motivation for sport activity and participation in university sports: A mixed-methods study. *BioMed Research International*, 2018(1), 1–8. <https://doi.org/10.1155/2018/9524861>
6. Diehl, K., & Hilger, J. (2015). Nutrition and physical activity during the transition from adolescence to adulthood: Further research is warranted. *International Journal of Adolescent Medicine and Health*, 27(1), 101–104. <https://doi.org/10.1515/ijamh-2014-0010>
7. Evans, B., Eys, M., & Wolf, S. (2013). Exploring the nature of interpersonal influence in elite individual sport teams. *Journal of Applied Sport Psychology*, 25(4), 448–462. <https://doi.org/10.1080/10413200.2012.752769>
8. Fenyves, V., Dajnoki, K., Kerezsi, D., & Bába, É. B. (2019). Analysis of sport motivation factors amongst Eastern European higher education students. *European Journal of Contemporary Education*, 8(4), 761–778. <https://doi.org/10.13187/ejced.2019.4.761>
9. Fitri, N. A. N. M., & Dewi, F. (2020). Motivation levels for youth participation in recreational sports : Intrinsic and extrinsic influencing factors. *Advances in Health Sciences Research*, 21(ICSSHPE 2019), 270–272.
10. Kaiser, H. F. (1974). An index of factor simplicity. *Psychometrika*, 39(1), 31–36.

<https://doi.org/10.1007/BF02294054>

11. Kondrič, M., Sindik, J., Furjan-Mandić, G., & Schiefler, B. (2013). Participation motivation and student's physical activity among sport students in three countries. *Journal of Sports Science and Medicine*, 12(1), 10–18.
12. Kucukibis, H. F., & Gul, M. (2019). Study on sports high school students' motivation levels in sports by some variables. *Universal Journal of Educational Research*, 7(3), 839–847. <https://doi.org/10.13189/ujer.2019.070325>
13. Lawler, M., Heary, C., & Nixon, E. (2020). Irish adolescents' perspectives on the factors influencing motivation in team sport. *Qualitative Research in Sport, Exercise and Health*, 00(00), 1–16. <https://doi.org/10.1080/2159676X.2020.1795706>
14. Memon, A. R., Ali, B., Attiq Ur Rehman Memon, I. A., & Feroz, J. (2018). Motivation and factors affecting sports participation: A cross-sectional study on female medical students in Pakistan. *Journal of the Pakistan Medical Association*, 68(9), 1327–1333. Retrieved from <http://www.embase.com/search/results?subaction=viewrecord&from=export&id=L623568922>
15. Miragaia, D. A. M., & Soares, J. A. P. (2017). Higher education in sport management: A systematic review of research topics and trends. *Journal of Hospitality, Leisure, Sport and Tourism Education*, 21(September), 101–116. <https://doi.org/10.1016/j.jhlste.2017.09.001>
16. Reilly, J. J., & Kelly, J. (2011). Long-term impact of overweight and obesity in childhood and adolescence on morbidity and premature mortality in adulthood: Systematic review. *International Journal of Obesity*, 35(7), 891–898. <https://doi.org/10.1038/ijo.2010.222>
17. Sawyer, S. M., Afifi, R. A., Bearinger, L. H., Blakemore, S. J., Dick, B., Ezeh, A. C., & Patton, G. C. (2012). Adolescence: A foundation for future health. *The Lancet*, 379(9826), 1630–1640. [https://doi.org/10.1016/S0140-6736\(12\)60072-5](https://doi.org/10.1016/S0140-6736(12)60072-5)
18. Vallerand, R. J., & Losier, G. F. (1999). An integrative analysis of intrinsic and extrinsic motivation in sport. *Journal of Applied Sport Psychology*, 11(1), 142–169. <https://doi.org/10.1080/10413209908402956>