

Analysis of Power Quality Disorders in KV Transmission using ANN and CWT Methods

JUGINDER PAL SINGH, ROHIT AGRAWAL

¹Department of Computer Engineering and Application
GLA UNIVERSITY, MATHURA
juginder.singh@gla.ac.in

²Department of Computer Engineering and Application
GLA UNIVERSITY, MATHURA
rohit.agrawal@gla.ac.in

Abstract: *With growing use of sensitive equipment, studies on power quality had developed to conduct data analysis on power quality. Wavelet transformation method has been very useful in investigating diverse types of events in power quality. Present paper associates the utilization of different wavelets at various scales and level of disintegration in examining real Power Quality (PQ) occasions from a link model or signal is produced utilizing MATLAB background. In this system voltage sag, swell, harmonics, momentary interruption, fault conditions and transient events are performed. The system proposed includes elements smaller than the traditional procurement process. In this method wavelet transform identified different power quality events and then classified them via Artificial Neural Network (ANN). Power quality disturbances are defined by the load received after neural network training. Separate MATLAB simulation model is designed to produce various power quality events like voltage sag, swell, passing disruption, harmonics, temporary and fault signals. ANN learning also wiped out MATLAB simulation using NN toolbox for power quality disturbance detection through the aliasing of voltage signals energy. Satisfactory results obtained in MATLAB simulink using such techniques.*

Keywords: *Wavelet transforms, Power quality, Neural Network*

1. Introduction

In the power system there are different types of faults but overhead transmission lines has highest rate of occurrence of fault because their exposure to different environmental conditions is more. Line failures caused by fire, rain, falling trees, fog and mist of salt on dusty insulating material are beyond the control of man.

Any irregular flow of electric current in power system is known as electric fault. Example, when flow of current eliminates the normal load which known as short circuit fault. When the circuit is break by some failure that fault is known as open circuit. The defensive apparatus detects fault conditions in power systems and activate circuit waves and other strategies to minimize service loss due to a breakdown. If a fault in a poly phase system can influence all phases uniformly then it is known as "symmetrical fault." The resulting fault is known as "asymmetric fault," which becomes more difficult to evaluate because of the simplification of presumption of equivalent current magnitude in all phases, when only certain phases are affected because the study of asymmetric fault form is complex "symmetrical components" are used for analysis. A symmetrical or balanced fault has an equal effect on all of the three phases. Faults in power

systems are essentially unbalanced in practical terms whereas fault does not have equal effect on all of the three phases.

Throughout this study, various approaches for transmission line protection focused on wavelet transformation are discussed focusing primarily on the specific methods for the detection, diagnosis and isolation of transmission line failures.

Some of these methods involved wavelet transform. High speed fault clearance is very important in a modern power system and different techniques have been developed to achieve this goal.

The framework proposed [1] for identification of authority excellence for power system conflicts by means of adaptive wavelet networks (AWNs). An AWN is a network that composes of two-sub system planning which contains of the wavelet transform and the probabilistic adaptive network. Symlet wavelet is utilized to derive characteristics by different disturbances to be adaptive probabilistic network investigates the relevant characteristics and achieves tasks for discrimination. AWN representations are applied for flexible execution, with autonomous goal modification and parameter adjusting for add-in and delete functions.

The Continuous Wavelet Transform (CWT) [2] on the sampled signals is utilized for identification of the power quality events and their time periods. annoyance amplitude is calculated by decaying, through the Discrete Time Wavelet Transform (DTWT), the signal in occurrence sub-bands in an optimized manner. The proposed strategy in this paper identified by high noise elimination, produced by both the measuring sequence and the system being evaluated and is designed for an agile identification of power quality events. In addition, it is also planned for potential use in both real-time measuring tackle and an off-line analytics tool.

2. Proposed Method

A. Wavelet Transform

In power system wavelet transformation technique has been another appropriate and effective signal representation processes. Wavelet analysis has become a fairly new procedure for power system and is successfully added by numerous investigators in power systems because of its time and frequency domain investigation capabilities [3],[4]. These are 2 areas that have many requests fares power quality research and power system security. Using the following equation, the description of a permanent wavelet transforms (CWT) for a specified signal $x(t)$ is specified in relation to a mother wavelet $\psi(t)$

$$CWT(a, b) = \frac{1}{\sqrt{a}} \int_{-\infty}^{\infty} x(t) \psi\left(\frac{t-b}{a}\right) dt \quad (1)$$



Fig.1. Flowchart of proposed approach

Where the scaling factor is a , and where the translation factor is b . All the factors t , a and b are continuous for CWT. Distinct configuration of t , b and a seen in equation

(1) utilized in wavelet transform procedure involving Discrete wavelet transform.

$$DWT(m, n) = \frac{1}{\sqrt{a_0}} \sum_k x(k) \varphi\left(\frac{k - nb_0 a_0}{a_0^m}\right)$$

The DWT description written in above equation that the initial and variables in (1) are altered to be numerals n , m 's functions. And k is an integer variable corresponds to the quantity of samples in an input signal.

Fig.2. Shows the useful implementation of DWT which is known as Multi-Resolution Analysis. Both high pass $h(n)$ and low pass $l(n)$ filter are used in this approach. To get the coefficients for detail (D1) and for approximation $e(A1)$ the results of both filters then are exterminating by two at the end of stage one. During second stage approximation coefficients are forwarded and same procedure is repeated. We get the signal at the end of the process, which decomposes to the required level as revealed in Fig.2. Where the unique measurement is frequency F , the indicator data collected by D1 is among frequency bands $f/4$ and $f/2$. Extracts data from $f/8$, and $f/4$, D3 Quotations data among $f/16$ and $f/8$ and A3 keeps the rest of the unique information 0 and $F/16$ Thus, we can efficiently gain meaningful data by source indicator hooked on dissimilar frequency bands, yet at the similar time matching the material to the time span associated. The increasing the wavelet's capacity, the more information can be retained following its decomposition.

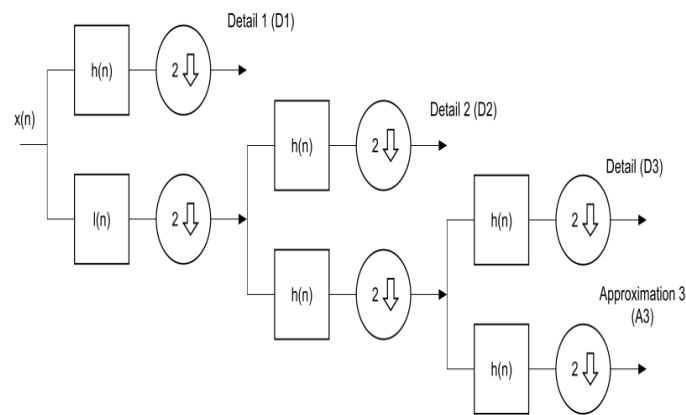

Fig.2. Wavelet multi-resolution analysis

Using the following Eqs. (3) & (4) the total energy and mean power can be expressed in terms of $x[n]$ signal.

$$P = \lim_{N \rightarrow \infty} \frac{1}{2N} \quad (4)$$

After an useful technique of decomposition we obtained the energy coefficients of each signals which are transferred to the neural network for internal and external classification of faults. Here data window length of the wavelet transform can change by variance in scale factor. After a good step of decomposition, we become the energy coefficient of discrete signals passed to the neural network to identify faults internally and externally. We are select amount of breakdown stage of Multi-resolution study and form of Mother Wavelet based on the best result occurs in projected research. This choice is completely focused on MATLAB Simulation Analysis.

B. Artificial Neural Network

Artificial neuron array is likewise state as a neural network. A mathematical model of the biological neuron is an artificial neuron in its humblest form. Biological neurons are seen as basic units in any nervous system for information processing.

Numerical model of a fake neuron depends on the accompanying, without characterizing its neurobiological legitimacy.

1. Neurons are the fundamental segment of a sensory system which handled the data.
2. Approaching data appears as sign that are shared through association joins
3. By association interface has a legitimate weight that duplicates the sign communicated.
4. Base on the predisposition and terminating edge every neuron has an inward activity, bringing about initiation work being added to the weighted total of the info sign to produce the yield signal. Furthermore, when information signals x_1, x_2, \dots, x_n are arrive at the neuron through association joins with relating loads w_1, w_2, \dots, w_n individually, the subsequent contribution to the neuron, called the net info, is the weighted total . On the off chance that the edge for terminating is b and the actuation work is f , at that point the neuron'

$$y = f \left(\sum_{i=1}^n w_i x_i \right)$$

In the first theoretical classical suggested by McCulloch and Pitts for artificial neurons, productions are double, and the purpose f is the step purpose.

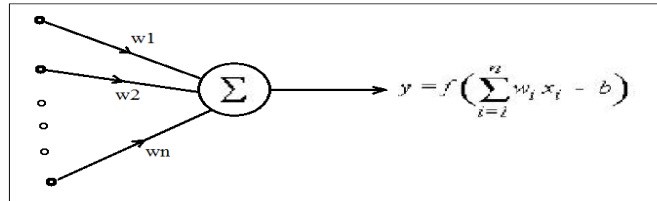

Fig.3. Mathematical classical for artificial neuron

Distinct by

$$f(x) = 1 \text{ if } x \geq 0$$

$$f(x) = 0 \text{ if } x < 0$$

so that the initiation of that neuron is

$$f\left(\sum_{i=1}^n (w_i x_i - b)\right) = 1 \text{ if } \sum_{i=1}^n w_i x_i \geq b$$

$$f\left(\sum_{i=1}^n (w_i x_i - b)\right) = 0 \text{ if } \sum_{i=1}^n w_i x_i < b$$

This is portrayed in Numeral 3. An artificial neuron is defined by the limitations $y = (w_1, w_2, \dots, w_n, b, f)$.

C. Potential Transformer (P.T)

Potential transformer utilized for operating of wattmeter potential coil and high voltage line relay coil during abnormal conditions. Potential modifier design is pretty comparable to a power transformer design then potentially transformer packing is continuously low, occasionally just a insufficient volt-ampere. In this system rating of potential transformer is such that instrument load receives a voltage between 100 to 120 volt. The voltage of the secondary winding of potential transformer which is connected across tripping circuit is 110 volt in system.

D. Working of Proposed Approach

A flow transformer (CT) and likely transformer (PT) are utilized to compute the three-stage yield flow and voltage signal of any broadcast line, transformer, producer or alternator, substation or other electrical hardware. This current sign for signal extraction is sent to wavelet change square. Phantom vitality of all individual stage current sign is estimated utilizing wavelet change methods in this segment. This current direction phantom vitality submits to neural system information. Neural Network as of now plan for various state of PQ unsettling influence. In light of preparing informational index Neural system offers its inclination for PQ type aggravations.

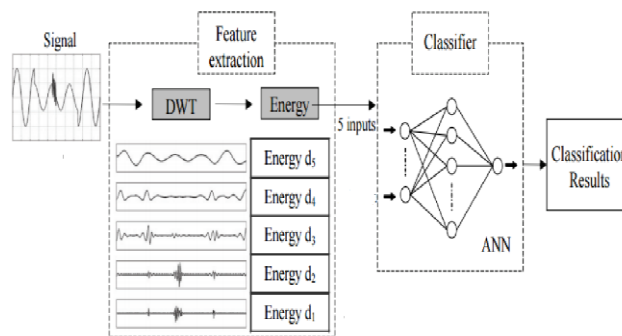

Fig. 4. Occupied of projected method

3. Simulation Results

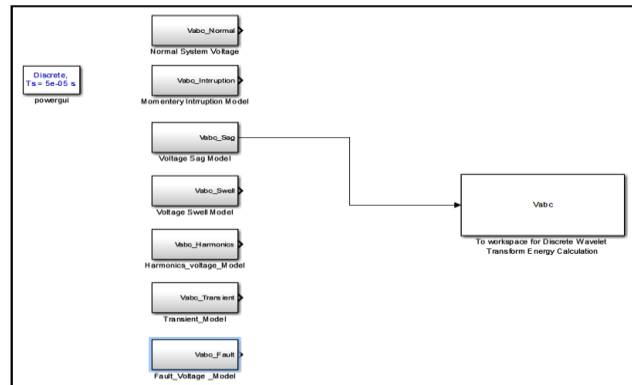

Fig.5. Complete MATLAB simulation for power quality analysis

Figure 5 shows the complete MATLAB simulation model for all power quality disturbance analysis. This model consists of seven subsystem model. Each subsystem model generates different power quality disturbance voltage signal like voltage sag, voltage swell, momentary interruption, transient, harmonics and fault voltages signals. This generated voltage signal get transfer to MATLAB workspace for performing wavelet transform or spectral energy calibration using wavelet toolbox.

TABLE .I. NORMAL VOLTAGE SUBSYSTEM MATLAB SIMULATION MODEL PARAMETER SPECIFICATION

Sr.No.	Name of simulation block	Parameter specification
1.	Three phase p voltage source (gen1)	Phase to phase rms voltage = 133 KV Phase angle of phase A = 0 degree; Frequency = 50Hz; Three phase short circuit level at base voltage = 100 MVA; Base voltage = 34.5 KV; X/R ratio = 7.
2.	Three phase transformer (xmer1)	Nominal power = 50 MVA; Frequency = 50 Hz; Winding1 (primary side); Ph-ph,rms voltage = 34.5 KV; R1 = 0.002 pu; L1 = 0.008 pu; Winding 2 (secondary side); ph-ph, voltage = 10 KV; R2 = 0.002 pu; L2 = 0.008 pu; Magnetizing resistance Rm = 500 pu; Magnetizing inductance Lm = 500 pu; Bothe primary and secondary are solidly grounded.
3.	Transmission line1 5Km	Number of phases = 3; Frequency for RLC specification = 50Hz; Positive sequence resistance r1 = 0.01273 Ohm/Km; Zero sequence resistance r0 = 0.3864 Ohm/Km; Positive sequence inductance L1 = 0.9337 mH/Km; Zero sequence inductance L0 = 4.1264 mH/Km; Positive sequence capacitor C1 = 12.74nF/Km; Zero sequence capacitor C0 = 7.75InF/Km; Line length = 5 Km
4.	Three phase fault block	Fault resistance Rf = 0.3 Ohm; Transition time = 0.1 to 0.3 second; Snubber resistance Rp = 1 MOhm
5.	Transmission line2 5Km	Number of phases = 3; Frequency for RLC specification = 50Hz; Positive sequence resistance r1 = 0.01273 Ohm/Km; Zero sequence resistance r0 = 0.3864 Ohm/Km; Positive sequence inductance L1 = 0.9337 mH/Km; Zero sequence inductance L0 = 4.1264 mH/Km; Positive sequence capacitor C1 = 12.74nF/Km; Zero sequence capacitor C0 = 7.75InF/Km; Line length = 5 Km
6.	Three phase series RLC load	Nominal phase to phase voltage = 440 V; Frequency = 50 Hz; Active power = 10 W; Inductive reactive power Ql = 0 VAR; Capacitive reactive power Qc = 20 VAR.

E. Power Quality Disturbance analysis using Wavelet Transform

In MATLAB simulink model is use for producing signals of power quality disturbances. A 34.5 KV Spreading network consists of three phase loads and one nonlinear load, simulating various disruptions of power quality events. Simulation specifications: Total simulation time=1sec, Time for detecting PQ disturbance from 0.2 to 0.4 second.

F. Normal Voltage

Analysis of the wavelet transform was performed on normal voltage waveform by allowing for db-1 mother wavelet decomposition up to five stages. Upto five levels of any condition in the model are

decomposed, five detail coefficients are obtained. For different types conditions in power system, the standard deviation of detail coefficients obtain are different is shown in fig.8.

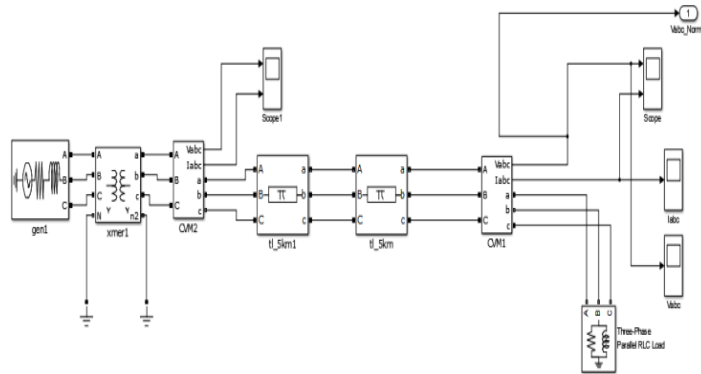

Fig.6.imitation representation for production of power quality annoyance voltage signals

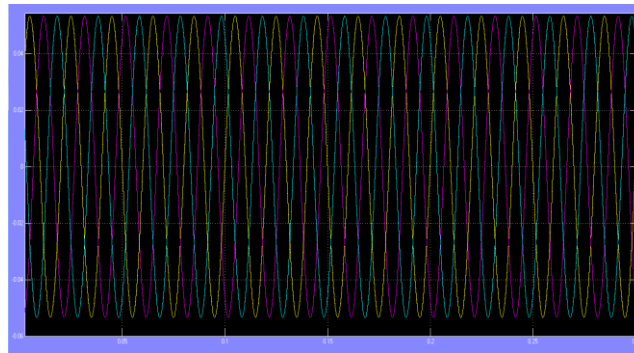

Fig.7. Normal voltage signal output

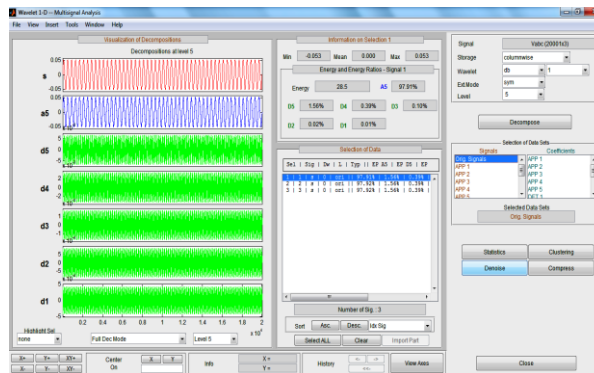

Fig.8. Wavelet multi-resolution investigation utilized Wavelet toolbox for normal voltage signal and energy calculation

G. Voltage Sag

We consider 34.5 KV broadcast representation by 440 Volt, 50Hz reactive load of 30 KVAR and active load of 10W to produce sag voltage in matlab simulation model. Sag produced in 0.1 to 0.4 seconds. The total simulation time is 1 second for the matlab model.

Analysis of the wavelet transform was performed on voltage sag waveform by since db-1 mother wavelet decomposition up to five stages. Up to five levels of any condition in the model are decomposed, five

detail coefficient are obtained. For different types conditions in power system, the standard deviation of detail coefficients obtain are different is shown in fig.10

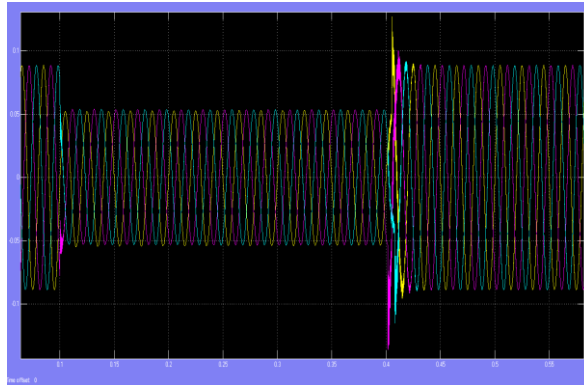

Fig.9. Voltage sag signal output

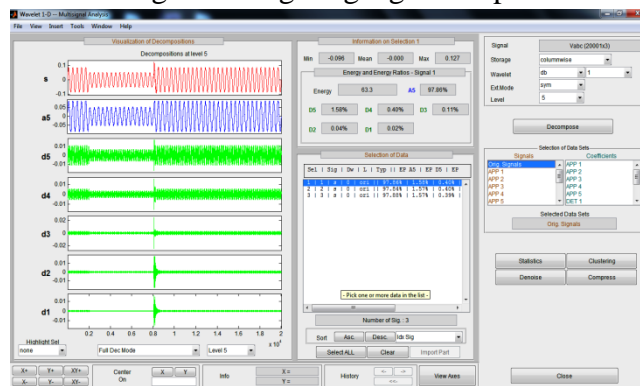

Fig.10. Wavelet multi-resolution investigation by means of Wavelet toolbox for sag

Voltage Swell

We deliberate 34.5 KV diffusion representations by 440 Volt, 50Hz capacitive load of 30 KVAR and active load of 10W for generating swell voltage in matlab simulation model. Swell produced in 0.1 to 0.4 seconds. Here the simulation is performed for 1 second in Matlab.

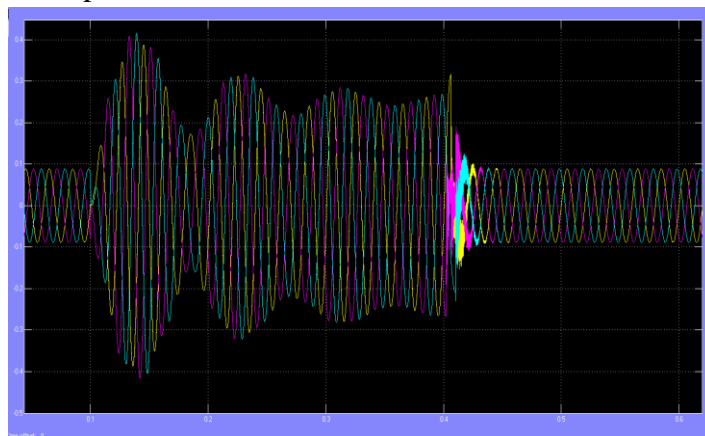

Fig.11. Voltage swells signal output

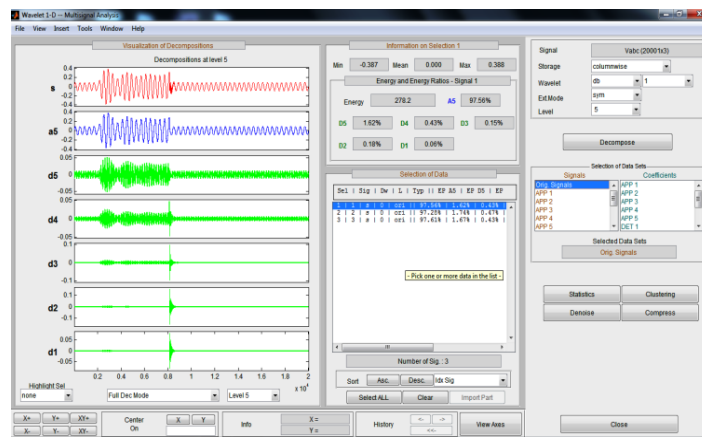

Fig.12. Wavelet multi-resolution investigation utilized Wavelet toolbox

Momentary Interruption Voltage

We believe 34.5 KV transmission representation by 440 Volt, 50Hz inductive load of 30 KVAR and energetic load of 30W for generating momentary interruption voltage in matlab simulation model. In between 0.1 to 0.4 seconds created momentary interruption. Here the simulation is performed for 1 second in Matlab.

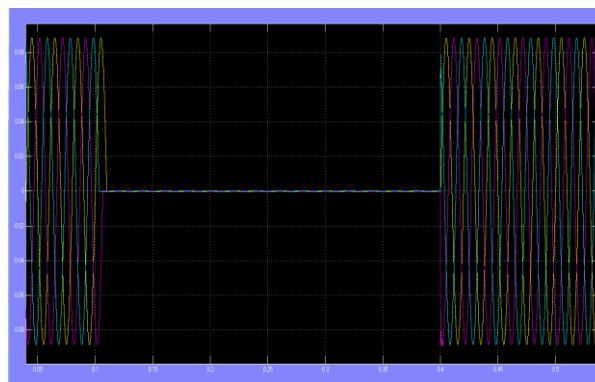

Fig.13. Momentary interruption of voltage signal output

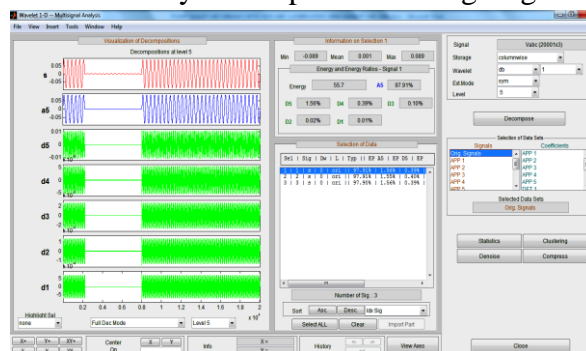

Fig.14. Wavelet multi-resolution investigation by means of Wavelet toolbox for momentary

H. Voltage with Harmonics

We deliberate 34.5 KV communication representations by series RL load division of inductance 22mH and confrontation 5 KΩ for the generation of voltage harmonics in matlab simulation model, Universal Bridge consists of diode resistance 100 MΩ snubber resistance.

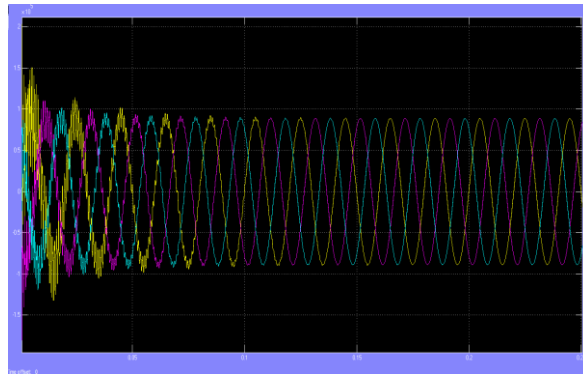

Fig.15. Harmonics using Matlab simulation model output

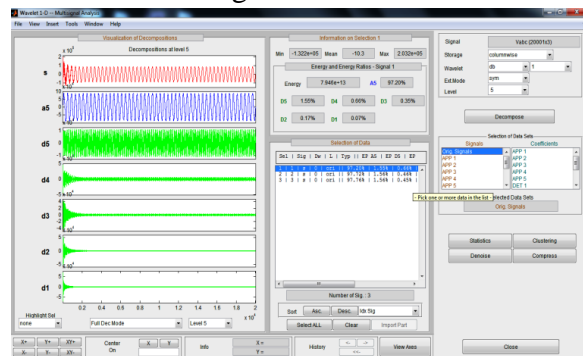

Fig 16. Wavelet multi-resolution investigation by means of Wavelet toolbox for Harmonics of voltage signal and energy computation

4. Transient Voltage

We deliberate 34.5 KV transmission model for transient voltage generation in matlab simulation model with transformer start rating 50MVA. High transients are produced during startup of transformer.

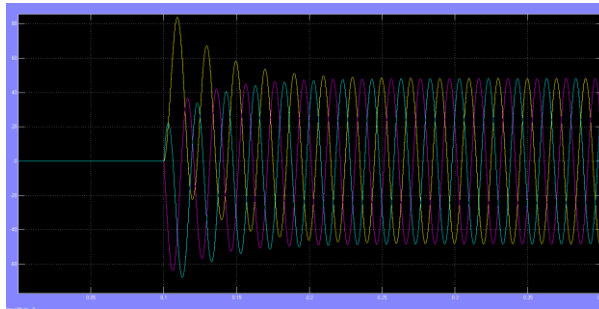

Fig 17. produced voltage transients utilized Matlab simulation model

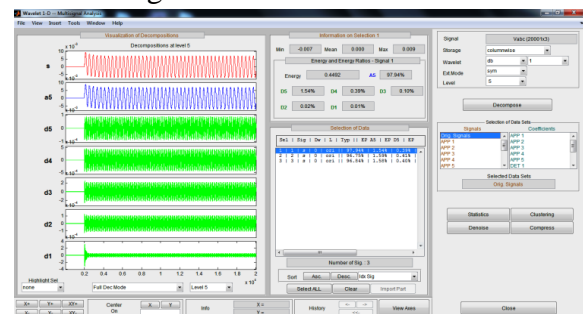

Fig.18. Wavelet multi-resolution investigation by means of Wavelet toolbox for Transient L. liability Voltage

For production of fault voltage signal in matlab reproduction representation, we believe 34.5 KV communication representations by different types of three phase fault on transmission line. Present we

simulate fault among Phase A to Ground for LG fault. Fault happen among 0.1 to 0.4 subsequent. Total simulation time is 1 second. The length of broadcast line is 10 km liability happen at 5 km in among line.

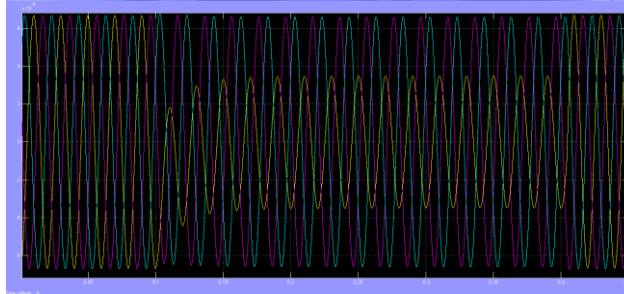

Fig.19. generate responsibility voltage signal utilized Matlab reproduction mode

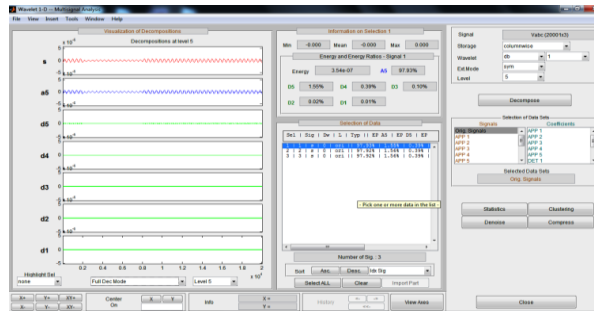

Fig.20. Wavelet multi-resolution investigation by means of Wavelet toolbox

5. Power Quality annoyance categorization Utilized Neural Network

Here educate the neural network by utilized spectral energy coordinates that are optimized by multi resolution investigation of wavelet. We relate energy coefficient upto level 5 of multi resolution investigation (MRA) for training neural network. Apply input as force of A5, D5, D4, D3, D2 and D1 to the neural network.

Data set input and target data set generated using disturbance cases above of power quality. Table II displays the training data collection for various power quality annoyance signals for train neural network.

TABLE 2: INPUT TRAINING DATA FOR NEURAL NETWORK

<i>PQ Disturbance</i>	<i>A5E</i>	<i>D5E</i>	<i>D4E</i>	<i>D3E</i>	<i>D2E</i>	<i>D1E</i>
Normal Voltage	97.91	1.56	0.39	0.10	0.02	0.01
Momentary interruption	97.91	1.56	0.39	0.10	0.02	0.01
Voltage sag	97.86	1.58	0.40	0.11	0.04	0.02
Voltage swell	97.56	1.62	0.43	0.15	0.18	0.06
Harmonics	97.21	1.56	0.65	0.36	0.18	0.07
Transient	97.95	1.55	0.38	0.11	0.02	0.01
LG Fault (AG)	97.93	1.55	0.39	0.10	0.02	0.01
LLG Fault (ABG)	98.04	1.47	0.37	0.09	0.02	0.01
LLL Fault (ABCG)	98.12	1.41	0.35	0.09	0.02	0.01
LL Fault (AC)	98.03	1.48	0.37	0.09	0.02	0.01

TABLE.3. TARGET TRAINING DATA FOR NEURAL NETWORK TABLE TYPE STYLES

<i>PQ Disturbance</i>	<i>ANN Target</i>
Normal Voltage	1
Momentary interruption	2

Voltage sag	3
Voltage swell	4
Harmonics	5
Transient	6
Fault voltage	7

Where, A5E = Approximate coordinate of spectral energy at level 5
 D5E = Detail coordinate of spectral energy at level 5
 D4E = Detail coordinate of spectral energy at level 4
 D3E = Detail coordinate of spectral energy at level 3
 D2E = Detail coordinate of spectral energy at level 2
 D1E = Detail coordinate of spectral energy at level 1

6. Training performance of Neural Network

We generate set of numbers for each form of power quality disturbances to train neural network for a 105-power quality disturbance event. For each power excellence trouble 15 complaint has been generated and during that power quality disturbance the neural networks gets trained for that condition using voltage signal energy.

Neural network hidden neurons were 10 during training on neural network. For this neural network training requires 27 period with 0.05992 Mean square error (MSE) by aim to genuine productivity. Neural network testing results on 5 % evaluation information, 5 % authentication information and 95 % exercise information seen in outlined 20.

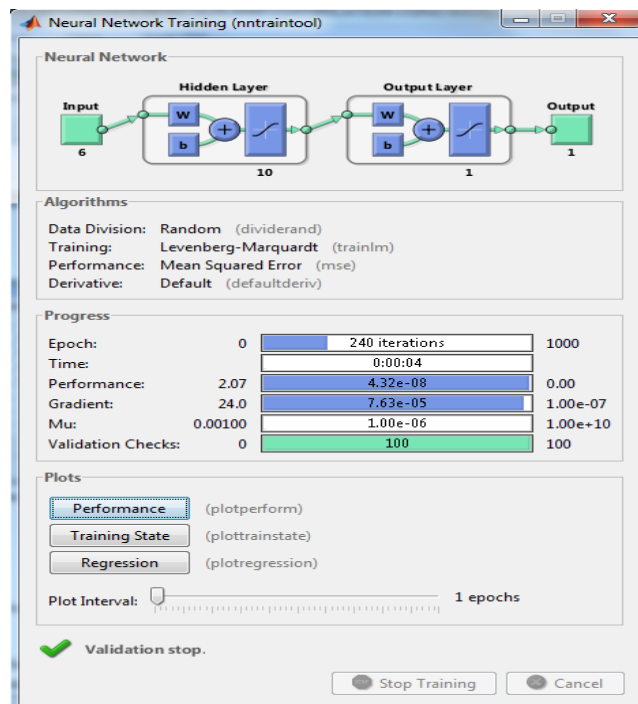

Fig.21. Training window during training of selected neural network in MATLAB simulation

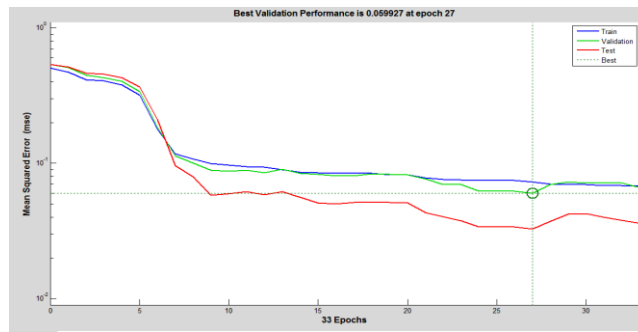

Fig 22. Training presentation of neural network throughout training by means of MATLAB

7. Outcomes from Neural Network

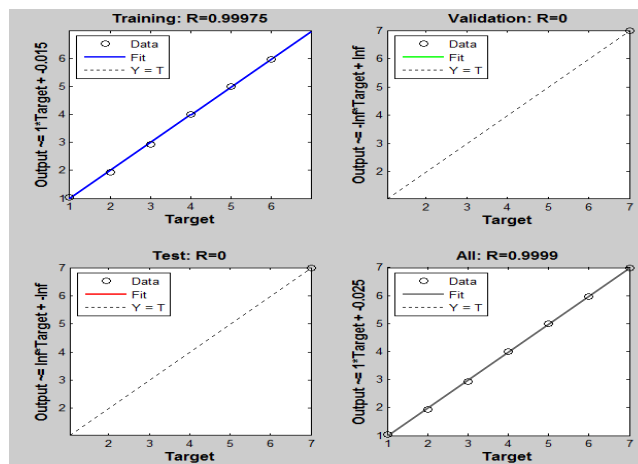

Fig.23. Actual output from neural network after training (Regression matrix)

Out of 90 force eminence aggravation occasion 71 PQ aggravation occasion order by means of 99 % exactness subsequent to preparing neural system. For the staying 19 PQ aggravation occasion neural system in confounding state don't effectively recognize the PQ unsettling influence. To develop the ANN precision or productivity new neural system model with various amount of move work and distinctive amount of concealed neurons plan basic. Here effort stretched out for upcoming effort. Figure 24 shows that a wide range of issue class arrangement completed by neural system. This ROC fig demonstrates the number of classifications viably order utilizing ANN.

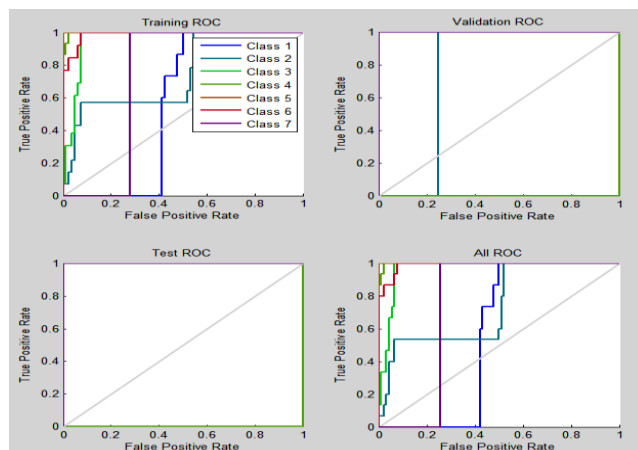

Fig.24.Reason of conversion (ROC) FOR ANN

8. Conclusion

Here Artificial Neural Network (ANN) and Wavelet Transform, this technique is utilized to distinguish and classify disturbance of power quality in the power system. The proposed method includes features that are less numerous than traditional recognition approaches. The feature haul out done the wavelet is being qualified for event classification by Artificial Neural Network. The obtained influence is utilized after training the neural network to identify the Power Quality (PQ) problems. The complete effectiveness of neural network for Power Quality trouble investigation is 99 %.

References

- [1] Lin, Chia-Hung, and Chia-Hao Wang. "Adaptive wavelet networks for power-quality detection and discrimination in a power system." *Power Delivery, IEEE Transactions on* 21.3 (2006): 1106-1113.
- [2] Angrisani, L., et al. "A measurement method based on the wavelet transform for power quality analysis." *Power Delivery, IEEE Transactions on* 13.4 (1998): 990-998.
- [3] C. H. Kim and R. Aggarwal, "Wavelet transforms in power systems part 1: General introduction to the wavelet transforms," *Power Eng. J.*, vol. 14, no. 2, pp. 81–88, Apr. 2000.
- [4] Kim, Chul Hwan, and Raj Aggarwal. "Wavelet transforms in power systems. II. Examples of application to actual power system transients." *Power Engineering Journal* 15.4 (2001): 193-202.
- [5] S. Santoso, E. J. Powers, W. M. Grady, and P. Hofmann, "Power quality assessment via wavelet transform analysis," *IEEE Trans. Power Del.*, vol. 11, no. 2, pp. 924–930, Apr. 1996.
- [6] A. H. Osman and O. P. Malik, "Transmission line distance protection based on wavelet transform," *IEEE Trans. Power Del.*, vol. 19, no. 2, pp. 515–523, Apr. 2004.
- [7] Youssef, "New algorithm to phase selection based on wavelet transforms," *IEEE Trans. Power Del.*, vol. 17, no. 4, pp. 908–914, Oct. 2002.
- [8] Mollanezhad Heydar-Abadi, M., and A. Akbari Foroud. "Accurate Fault Classification of Transmission Line Using Wavelet Transform and Probabilistic Neural Network." *Iranian Journal of Electrical and Electronic Engineering* 9.3 (2013): 177-188.
- [9] Varun K L Srivastava, N. Chandra Sekhar Reddy, Dr. Anubha Shrivastava, "An Effective Code Metrics for Evaluation of Protected Parameters in Database Applications", *International Journal of Advanced Trends in Computer Science and Engineering*, Volume 8, No.1.3, 2019. doi.org/10.30534/ijatcse/2019/1681.32019
- [10] Varun K L Srivastava , N. Chandra Sekhar Reddy , Dr. Anubha Shrivastava, "An efficient Software Source Code Metrics for Implementing for Software quality analysis", *International Journal of Emerging Trends in Engineering Research*, Volume 7, No. 9 September 2019.
- [11] Abdel-Galil, T. K., et al. "Power quality disturbance classification using the inductive inference approach." *IEEE Transactions on Power Delivery* 19.4 (2004): 1812-1818.
- [12] Biswal, Birendra, Pradipta K. Dash, and Bijaya K. Panigrahi. "Power quality disturbance classification using fuzzy C-means algorithm and adaptive particle swarm optimization." *IEEE Transactions on Industrial Electronics* 56.1 (2009): 212-220.
- [13] Santoso, Surya, et al. "Power quality assessment via wavelet transform analysis." *IEEE transactions on Power Delivery* 11.2 (1996): 924-930.

- [14] Santoso, Surya, et al. "Power quality assessment via wavelet transform analysis." *IEEE transactions on Power Delivery* 11.2 (1996): 924-930.
- [15] Perunicic, B., et al. "Power quality disturbance detection and classification using wavelets and artificial neural networks." *Harmonics and Quality of Power Proceedings, 1998. Proceedings. 8th International Conference On. Vol. 1. IEEE, 1998.*
- [16] Dash, P. K., et al. "Power quality disturbance data compression, detection, and classification using integrated spline wavelet and S-transform." *IEEE Transactions on Power Delivery* 18.2 (2003): 595-600.
- [17] Sharma, Ashish, Anant Ram, and Archit Bansal. "Feature Extraction Mining for Student Performance Analysis." *Proceedings of ICETIT 2019. Springer, Cham, 2020. 785-797.*
- [18] Sharma, Ashish, and Dhara Upadhyay. "VDBSCAN Clustering with Map-Reduce Technique." *Recent Findings in Intelligent Computing Techniques. Springer, Singapore, 2018. 305-314.*
- [19] Sharma, Ashish, Ashish Sharma, and Anand Singh Jalal. "Distance-based facility location problem for fuzzy demand with simultaneous opening of two facilities." *International Journal of Computing Science and Mathematics* 9.6 (2018): 590-601.
- [20] Ram, Anant, et al. "A density based algorithm for discovering density varied clusters in large spatial databases." *International Journal of Computer Applications* 3.6 (2010): 1-4.
- [21] Kulshrestha, Jagrati, and Anant Ram. "An Analytical Study of the Chain Based Data Collection Approaches." *2019 4th International Conference on Information Systems and Computer Networks (ISCON). IEEE, 2019.*
- [22] Agarwal, Rohit, A. S. Jalal, and K. V. Arya. "A review on presentation attack detection system for fake fingerprint." *Modern Physics Letters B* 34.05 (2020): 2030001.
- [23] Mishra, Ayushi, et al. "A robust approach for palmprint biometric recognition." *International Journal of Biometrics* 11.4 (2019): 389-408.
- [24] Singh, Anshy, Shashi Shekhar, and Anand Singh Jalal. "Semantic based image retrieval using multi-agent model by searching and filtering replicated web images." *2012 World Congress on Information and Communication Technologies. IEEE, 2012.*
- [25] Shekhar, Shashi, et al. "A WEBIR crawling framework for retrieving highly relevant web documents: evaluation based on rank aggregation and result merging algorithms." *2011 International Conference on Computational Intelligence and Communication Networks. IEEE, 2011.*
- [26] Verma U., Bhardwaj D., 2020 "Design of Lightweight Authentication Protocol for Fog enabled Internet of Things - A Centralized Authentication Framework", *International Journal of Communication Network and Information Security* Vol 12, No 2 (2020) pp. 162-167