

# An Advanced Power Control Method of A Hybrid AC/DC Micro Grids

Nerella Vijay kumar<sup>1</sup>, T Sai Kiran<sup>2</sup>, Abdi D Prasad<sup>3</sup>, G V K Murthy<sup>4</sup>, V V Raghavulu<sup>5</sup>  
1PG Student, Dept of EEE, PACE Institute of Technology & Sciences, Ongole, AP, India.

<sup>2,3,5</sup> Assistant Professor, Dept of EEE, PACE Institute of Technology & Sciences, Ongole, AP, India.

<sup>4</sup> Professor, Dept of EEE, PACE Institute of Technology & Sciences, Ongole, AP, India

## Abstract

*A multi-terminals AC/DC hybrid microgrid within one AC terminal along with two DC terminals is constructed. Then approached framework repose about cascade H-bridge (CHB) converter system established as two duel active bridges (DAB) along with AC grid interfaced converter established DC sub grid interfacing the connect double isolates DC terminal. So as to diminish the quantity of intensity transformation stages and force gadgets, the DAB converter system was legitimately associated with cascade h-bridge DC rails as per the framework activity necessity. Then conquer the imbalance network flows and DC rail voltage issues brought about to changed framework design with just two power transformation arranges, an improve technique is approached throughout the zero-grouping voltage infusion into cascade h-bridge converter system. What's more, to keep away from the contentions between zero-arrangement voltage infusion and the voltage/current guideline of the framework, then effects about to controlled parameters into the framework steadiness and dynamic reaction are explored. Assessment simulations ahead of three terminals and five terminals DC/AC microgrids seen their summed up viability of the approached three-stage AC current along with DC bus voltage adjusting strategy.*

**Keywords:** Microgrid, Cascade H-bridge (CHB), Duel Active Bridges (DAB), Distribution Network.

## 1. INTRODUCTION

Long ago, when environmental impact about world's energy infrastructure has become an increasing concern. Therefore, much research has been dedicated to increasing the efficiency of energy resources. Microgrids are useful structures in allowing for efficient management of distributed resources such as small scale distributed generators and renewable energy resources. The microgrid structure allows for more optimal operation with potential results being reduced emissions, and fewer power interruptions. Microgrids can be comprised a complex combination about dc along ac energies; ac along dc burdens; and the electronics interfaces. As discusses, and microgrid system essentially small, local revision about to grid. Microgrids integrate various renewable and non-renewable power sources along with storage. Then definition about a microgrid good standard, but can vary slightly. In three basic properties of a microgrid are discussed. The first property is that there must be clearly defined electrical boundaries. These electrical boundaries are defined such that the microgrid is capable of operating as an isolated system. The second characteristic is that there must be a master controller to manage distribution power resource along with burden as to control within the defined electrical boundary. Lastly, the total power generation should excess then highest burden capacity so that the system can operate in islanded mode. That is, the microgrid is capable of operating independent of the utility grid. Ideally, an optimal power flow algorithm should take into account all ac and dc components in order to arrive at a solution that is as representative of the actual system as possible. Secure supply of energy is critical to sustain our modern civilization. Electric force frameworks has planned and built to be profoundly dependable; then recurrence and term of intensity blackouts are low when contrasted with other designing frameworks of a practically identical multifaceted nature, for example the cell correspondence framework. Though high unwavering quality has consistently been the objective of intensity framework organizers/administrators then ongoing flood of serious tempests, which cause boundless force blackouts and critical monetary misfortunes, uncovered the way that the current influence framework are not flexible enough against catastrophic events. Force

frameworks are helpless against catastrophic events as well as to some other damaging occasions, for example digital assaults. As indicated by a Journals report, an assault on just multi substations could causes a monstrous power outage. Accordingly, if the nationality expanding the framework versatility, along with self-recuperating ability. Contrasted with the principle power framework, a versatile matrix is less inclined to fall flat, and all the more significantly, in the event that it is to bomb because of low-likelihood high-sway occasions, for example, human blunders, it will have the option to in part continue the force gracefully, and reestablish the administration quicker and all the more deftly. This prompted the presentation of shrewd matrix, with a significant job expected to be played by sustainable power source based microgrids. Keen matrices are adaptable force lattices that have risen with the presentation of new innovations and highlights, for example expanded reliance on Information Communication Technology, high sustainable power source entrance, Advanced Metering Infrastructure, micro grids along electric vehicle. Smart grid implementation is expected to lead to various benefits, such as efficient conversion of electricity, reduction of peak demand, faster power restoration subsequent to blackouts and good combining about to consumer-personal power production generation (e.g. microgrids).

## 2. SYSTEM MODELING

The traditional three-terminal DC/AC microgrid framework as a rule comprises of three force change stages, as appeared in Fig. 1. The main stage is the DC/AC converters about CASCADE H-BRIDGE state; that subsequent level that DC/DC converter system about DAB state; then final state that DC/DC converters about to conventional double direction boost type converter system, where the ideal DC voltage can be acquired by the extra DC voltage change.

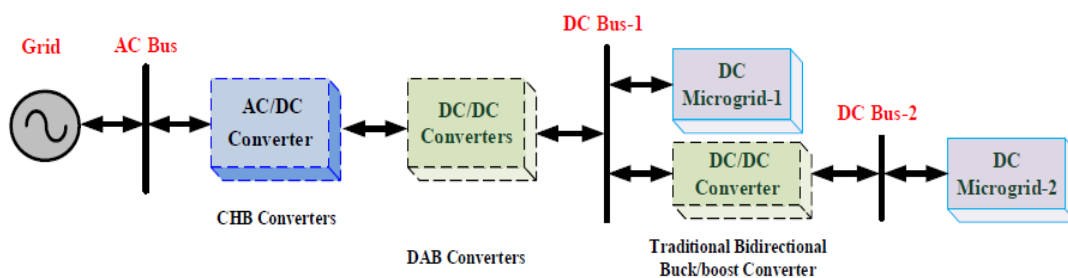

Fig. 1. The conventional three stage DC/AC microgrid system.

For this situation, as every one of three force transformation case endures that low decoupled, it is generally simple to control power stream, voltages along with currents. Be that as it may, this crossover microgrid structure is associated with more force gadgets which lead to bring down productivity because of the selection of extra DC/DC transformation stage. So as to decrease equipment cost of intensity gadgets with diminished number of intensity change organizes, this average three-terminal half and half AC/DC microgrid structure has not created in investigate. By the regular voltage adjusting control of matrix interfacing AC/DC converter and mainstream stage move control technique for DC/DC converters into approached three-terminal crossover AC/DC microgrid, appeared in Figure. 1 or three-terminal AC flows or cells' DC capacitor voltage about to cascade h-bridge converter system might be uneven. The uneven conditions endure brought about by the bungled DC power system into DC microgrid systems. Also, when the single-stage lattice issue happens at the same time, because of the development of the DC organize topologies about to DAB converter system, those uneven conditions are increasingly muddled self-evident. Three-stage AC flows and DC capacitor voltages balanced assume a significant job into force quality and safety dependable activity by microgrid framework, separately. That commendable referenced to unsatisfactory DC capacitors voltage adjusting control technique, voltage ascent by something DC capacitor in expand the voltages push and lessen the activity life of intensity module. In that extreme stage, these truly harmed because of overvoltages, influencing that typical activity about microgrid framework. The situation being what it is by confused DC microgrid power move along framework voltage lists, and then controlled goals about both three-stage AC current along DC capacitors voltage adjusting having once in a while approached. There is three-stage AC/DC microgrid within both DC terminals along single AC

terminal endures proposed in Figure.2 along with legitimately associated with three-stage medium-voltages lattice. Then comprises about AC/DC converters system cascade h-bridge converter system along with conservative DC/DC converter DAB converter system, made out of two gathering of DC/DC converter system, in particular DC/DC converter system with DC/DC converter system. Consider the effect of different association examples of DAB converter system, in particular unique wire association compares cascade h-bridge converters yields and DAB converter system inputs, along distinctive DAB sub modules numbering each every DC/DC converter system, the approached three-stage AC/DC microgrid having different sorts of inner construction. Then DAB converters system branch into different burdens is associated within that cascade h-bridge modules' yields arbitrarily, then this problems about capacitor voltages uneven is to illuminated about approached regulation conspire. In this manner, then DAB converters association designs is too delineated in Figure.2. is shown.

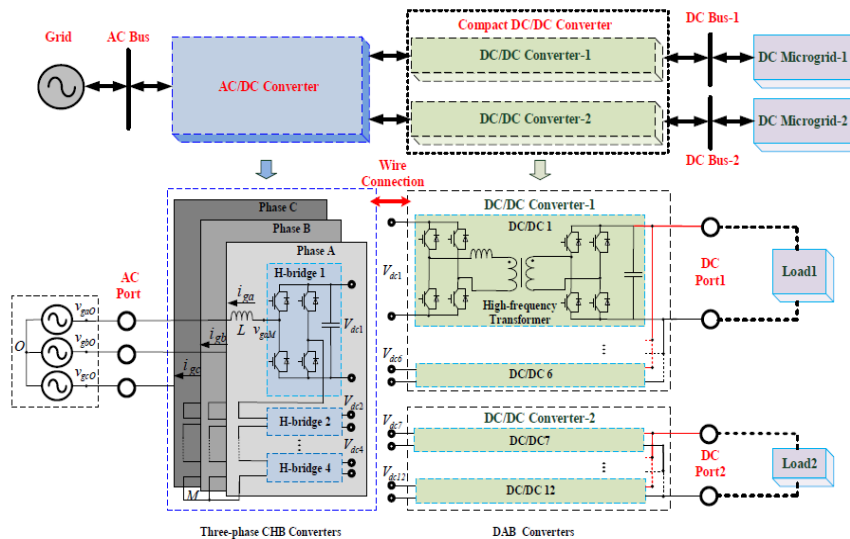

Fig. 2. Approached three stage hybrid DC/AC microgrid system.

The attributes of approached three-stage AC/DC microgrid is presented as discussed:

- 1) Double DC yield terminal having that highlights by most controlled adaptability along upgraded dependability. Distinctive sort by burdens, for example, straight burden and nonlinear burden is associated with various DC ports dependent on equivalent DC transport voltage the two diverse DC transport voltage can be set to fulfill variable transport voltage needs. Contrasted and single DC yield port, the force flexibly unwavering quality of DC organize is improving if there should arise an occurrence of a couple of H-spans disappointments.
- 2) Any way customary line-recurrence transformer, the medium level-voltages or highest-voltages network is to straightforwardly associate to starting-ending B construction.
- 3) Contrasted and that traditional three-stages DC/AC microgrid, that extra DC/DC transformation cases about to subsequent DC transport is to expelled with the goal that equipment cost of intensity gadgets will be decreased and the framework productivity will be quality
- 4) Then seclusion capacity about intensity transmission endures coordinated into DAB converter system to huge-recurrence transformer, with the most reduced along financially savvy than line-recurrence another parts.

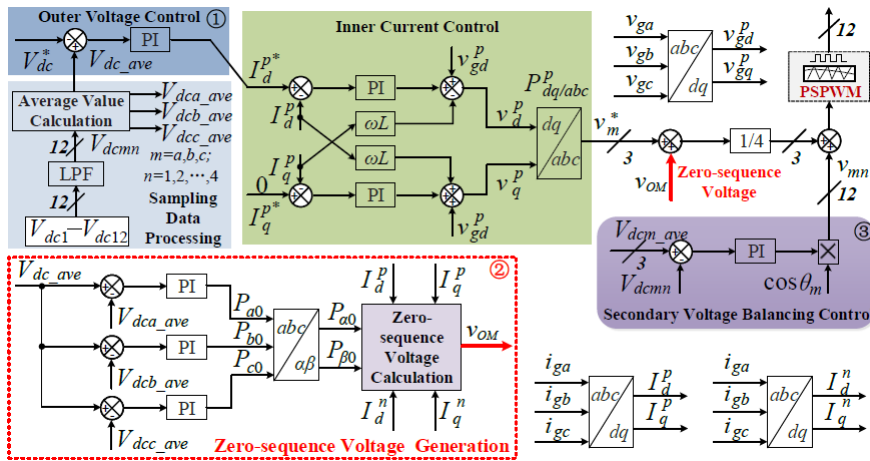

Fig.3. The proposed method in the three-terminal hybrid AC/DC microgrid.

At that point, these last PWM references by every H-connect stage  $v_{mn}$  where  $m=a, b, c; n=1$  to 4 abide prepared about the regular stage move PWM controls the relating exchanging signs of DC/AC converter system. At long last, then controllers by DC-DC converter system endures performance the regular stage move controls strategy into comparing stage move point. The stage move point endures managed to the basic PI control as per that voltage mistake distinct DC transport voltages along this voltage base value. In the outer voltage control, by PI controller according to the voltage error between  $V_{dc\_ave}$  and DC voltage reference  $V_{dc}^*$ , the positive-sequence d-axis current reference  $I_d^{p*}$  is got to adjust the overall active power interaction between AC/DC converter and grid. Meanwhile, positive-sequence q-axis current reference  $I_q^{p*}$  is set to regulate overall reactive power. To the external voltage controls, about PI control as per that voltage mistake among  $V_{dc\_ave}$  along DC voltages base value  $V_{dc}^*$ , that positive-succession d hub current base  $I_d^{p*}$  endures get that chance to alter the general dynamic force association distinct DC/AC converters along with utility. In the interim, positive-succession q-pivot current base  $I_q^{p*}$  endures setting into control in general receptive energy.

### 3. SIMULATION RESULTS

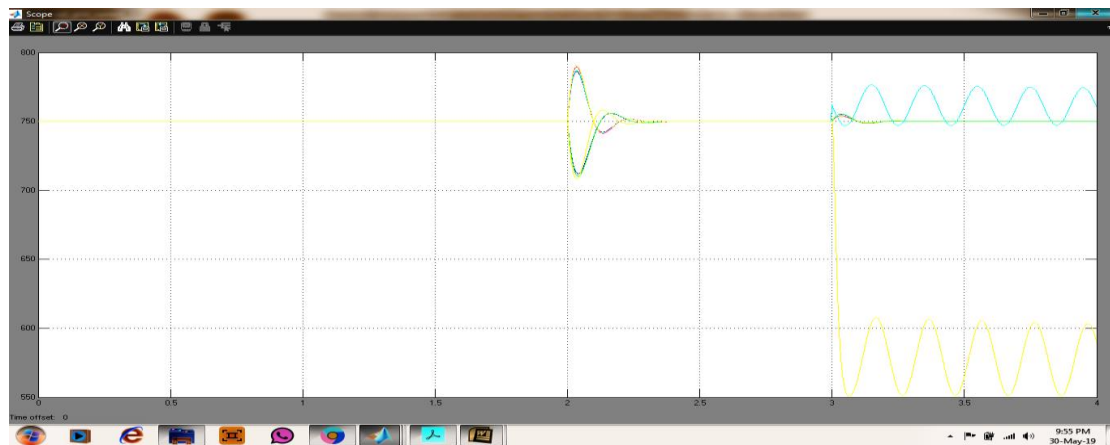

Fig. 4. DC Voltages of capacitor about to DC/AC converters about to traditional methodology.

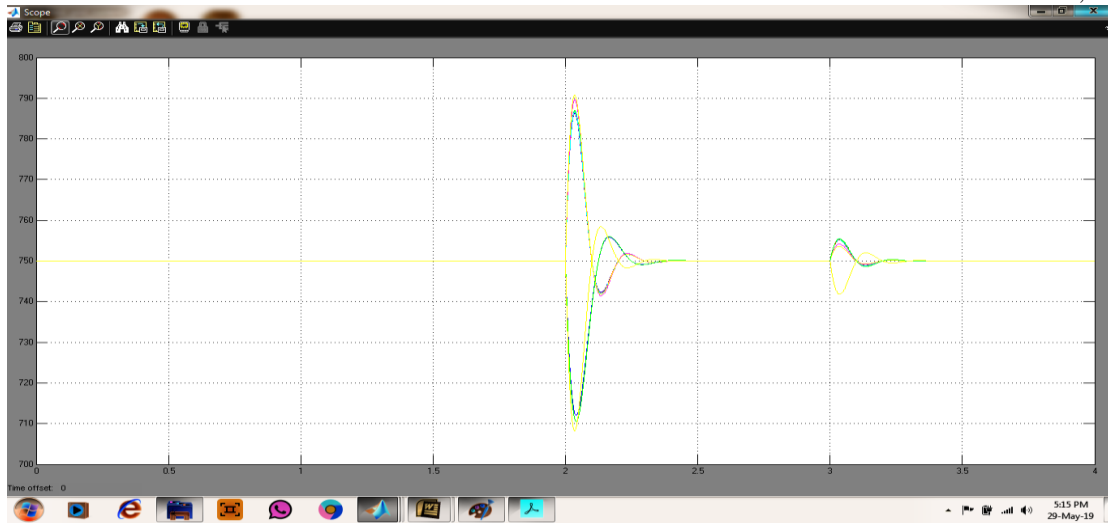
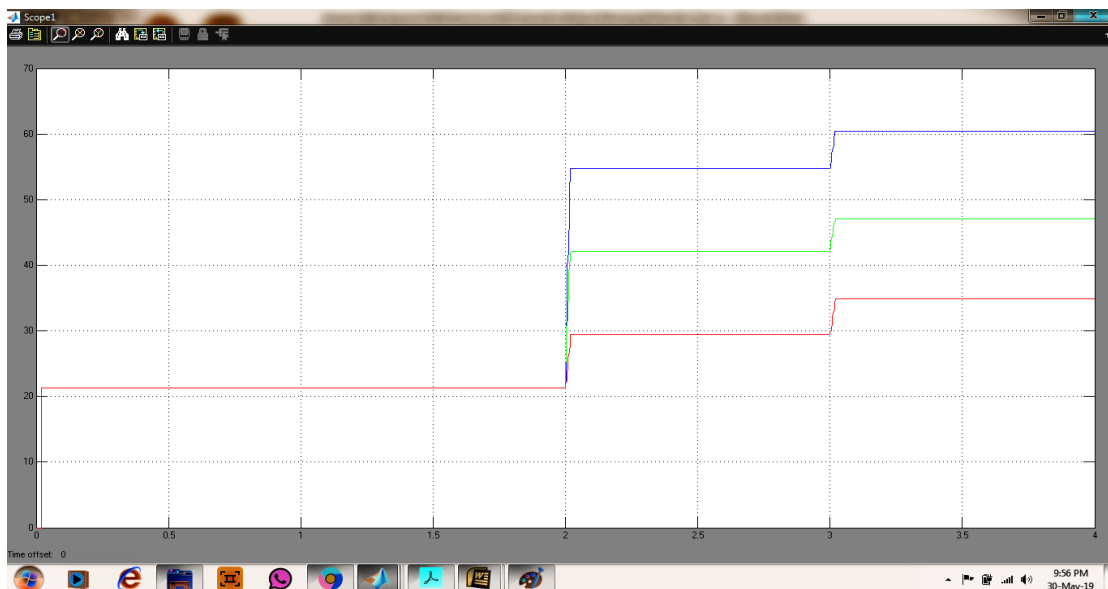

Fig. 5. DC Voltages of capacitor about to DC/AC converters about to approached methodology.

Voltages of capacitor in DC/AC converters about customary strategy are appeared in Figure. 4. This plainly observed that DC voltages of capacitor abide adjusted in case 1 along case2, and unequal case 3 also. Case 2, voltage of DC stage B is about 100.2 V vacillations along other than little modification. Case 3, this tends into seen that's all DC voltages of capacitor by stage C is terminate generously into correspondingly 550.1 V along the DC voltages of capacitor is insecure states, genuinely influencing power quality issues. Here the examinations, in the approach technique, these abide constantly adjusted to rearranging that between stage power, appeared in Figure. 5. The conventional technique, then the bungled DC type power brought about by various burdens are moved, a similar voltage base esteem is disseminated for every H scaffold by DC/AC converters dependent on the PWM controls. Thus, three-stage AC flows abide lopsided if there should arise an occurrence by DC voltages of capacitor balance. In any case, by the proposed strategy, the dynamic zero-succession voltage is infused to change these H-spans reference voltage estimations by DC/AC converters system along last exchanging time estimations by intensity models abide balanced. As it were, in stage C by overwhelming burden, then this on switch time esteems abide expanded within zero-grouping voltage infusion; then again, in stage A of the light burden, these abide expired.



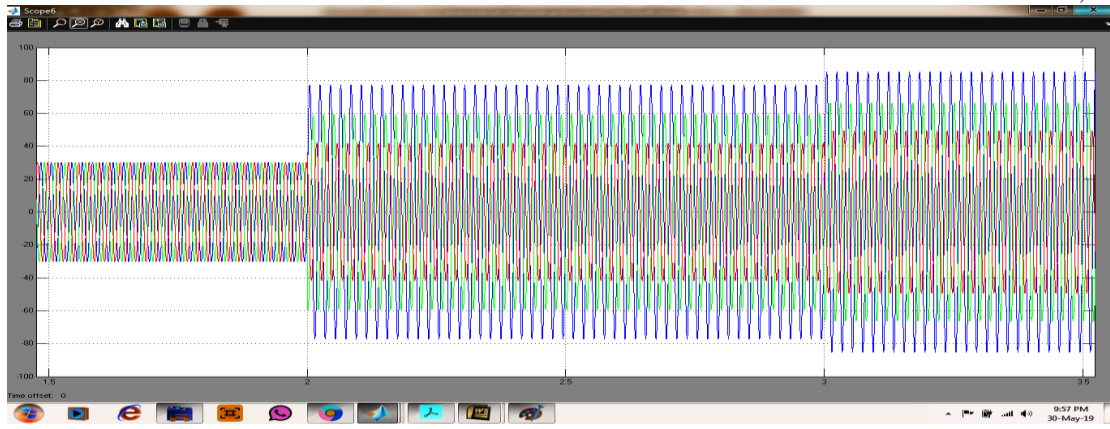

Fig. 6. Utility currents along transient currents about to traditional methodology.

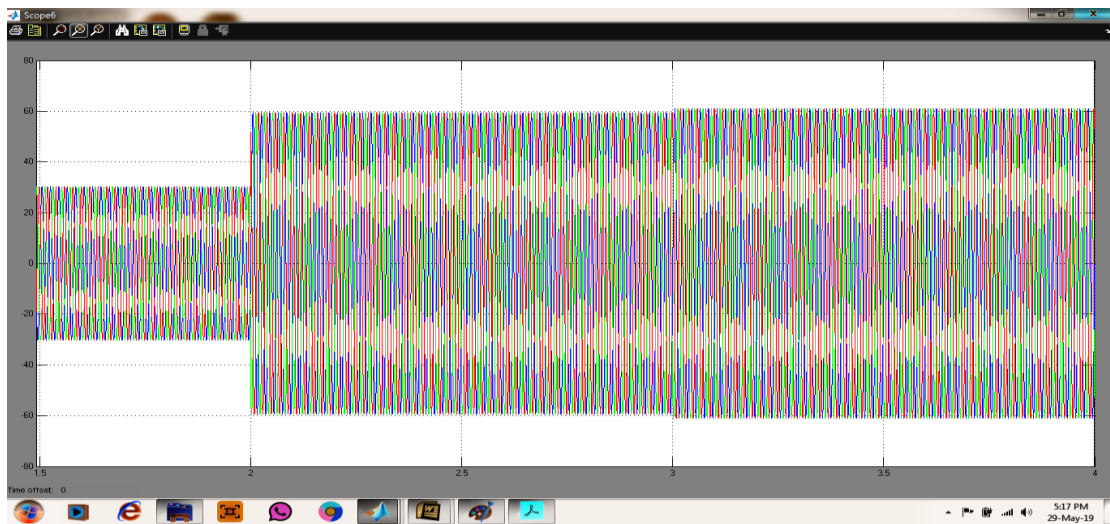
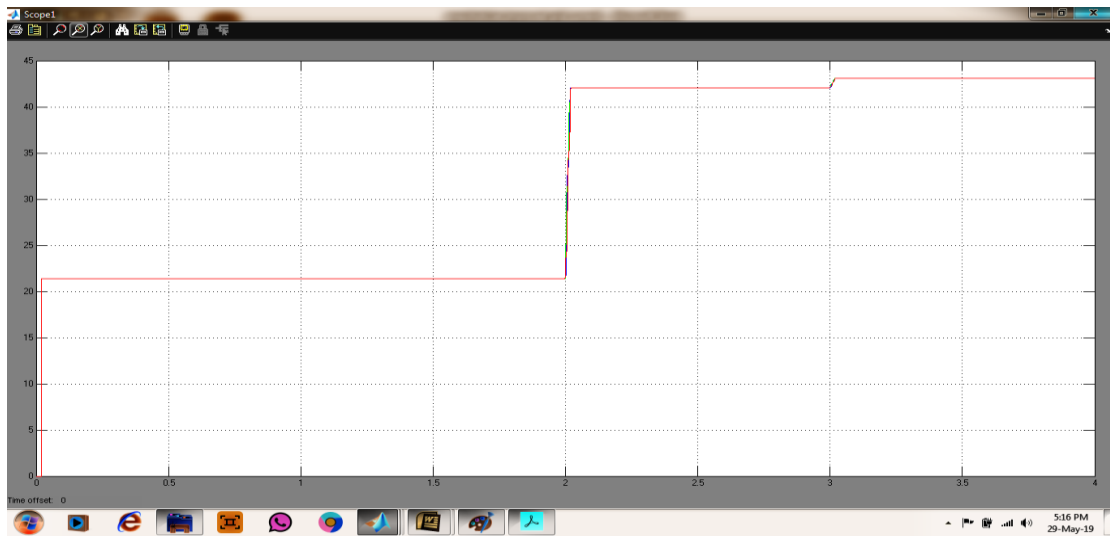

Fig. 7. Utility currents along transient currents about to approached methodology.

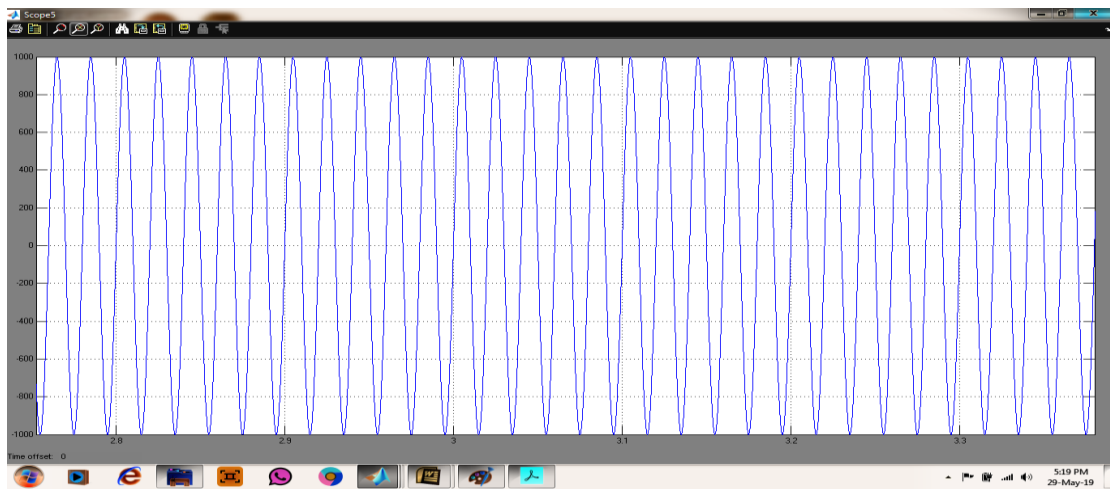
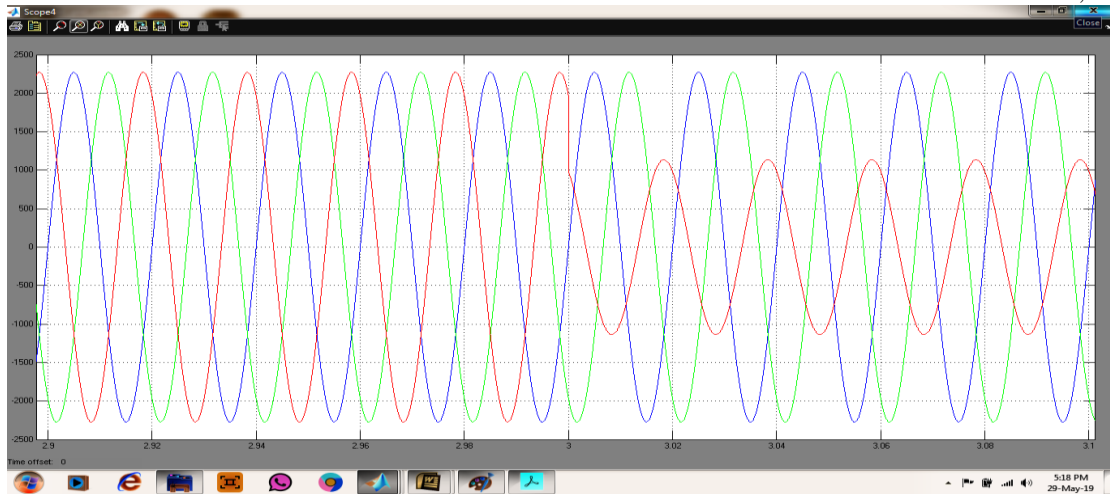
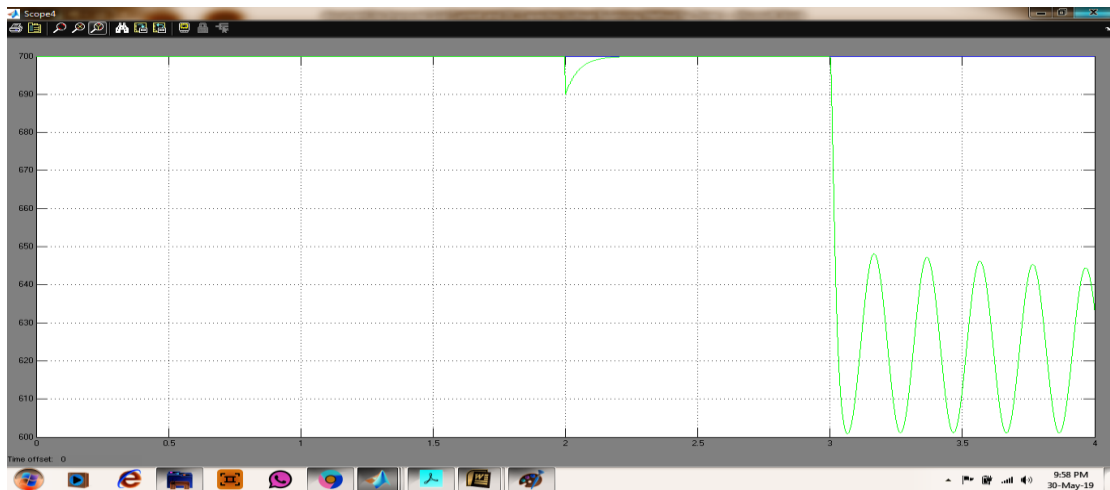
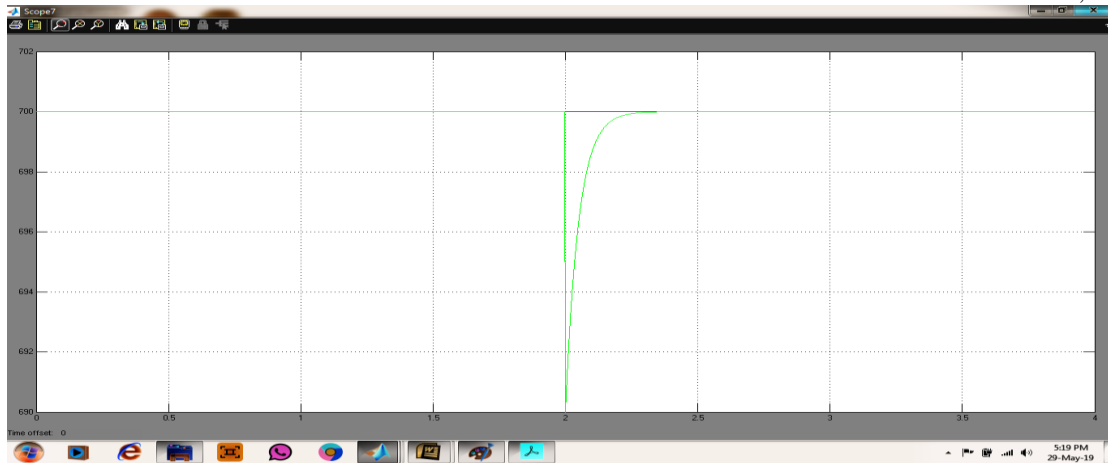

Fig. 8. The zero sequence voltages along with the utility voltages about to approached methodology.



(a) DC/AC converter system control about to traditional methodology.



(b) DC/AC converter system control about to approached methodology

Fig.9. DC voltages by DC/DC converter to traditional and approached phase-shifted control methodology.

The three phase currents at the grid side along transient currents of previous system are appeared in figure 6. Here it can see that grid currents balanced in the case1, unbalance currents also shown in case 2 and finally due to because of unbalanced side power also observed. The difference of comparison of two cases 2 is 25.9 A and case 3 is 29.9 A. So in the proposed methodology it is balanced by using of ZSVI dynamics is shown in figure 7. Then comparison of currents of RMS values is 0.23A in case1 and 0.71A in case 3. To avoid this unbalanced conditions DC-AC converter systems within the three phases due to because of not matching DC voltage levels and utility sag conditions, then the this conditions is to used Zero sequence method to induces the voltage to the cascade h-bridge converter side appeared in the figure 8. In various analysis's, the different zero sequence voltages is appeared in the figure 8 (a) in case 1 and 8 (b) is case 3, is shown. If this DC-DC converter system control of previous controlled method the voltages is appeared in figure 9. The adjusting control aftereffects of DC capacitors voltage affect the controlled execution by DC transport voltage by DC/DC converter system about ordinary stage moved control technique, because of the physical association of DC/AC converters along DAB converter system. In this manner, DC transport voltage are insecure in case 3 is, appeared in Figure. 9(a) is shown. The noticed that other DAB controlled strategies are utilized into keep up DC transport voltages about reference point an incentive because of the critical preferred position of wide-extend activity. At starting-ending DC/AC converters are constrained about approached strategy, these are into consistent case DC transport voltage base value, appeared in Figure. 9(b) is shown.

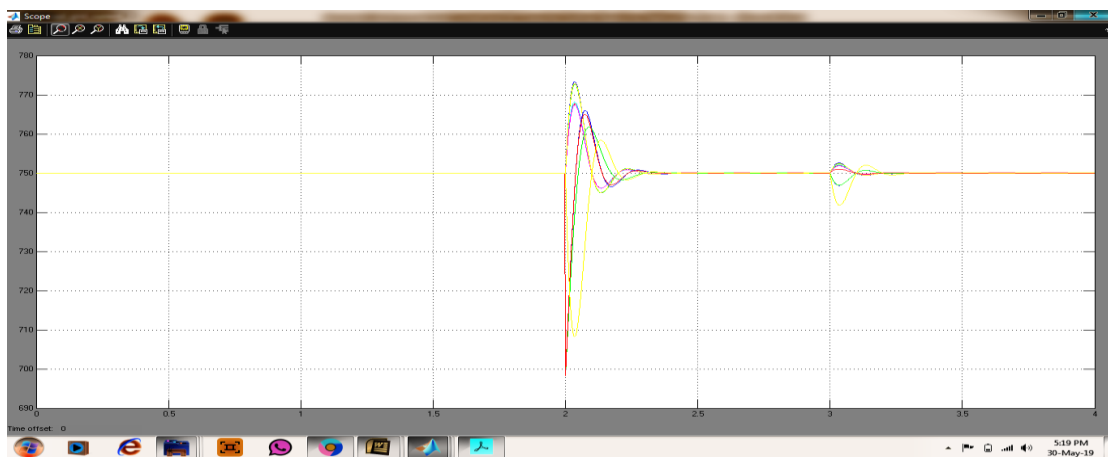

Fig. 10. DC capacitor voltages of AC/DC converter by the proposed method.



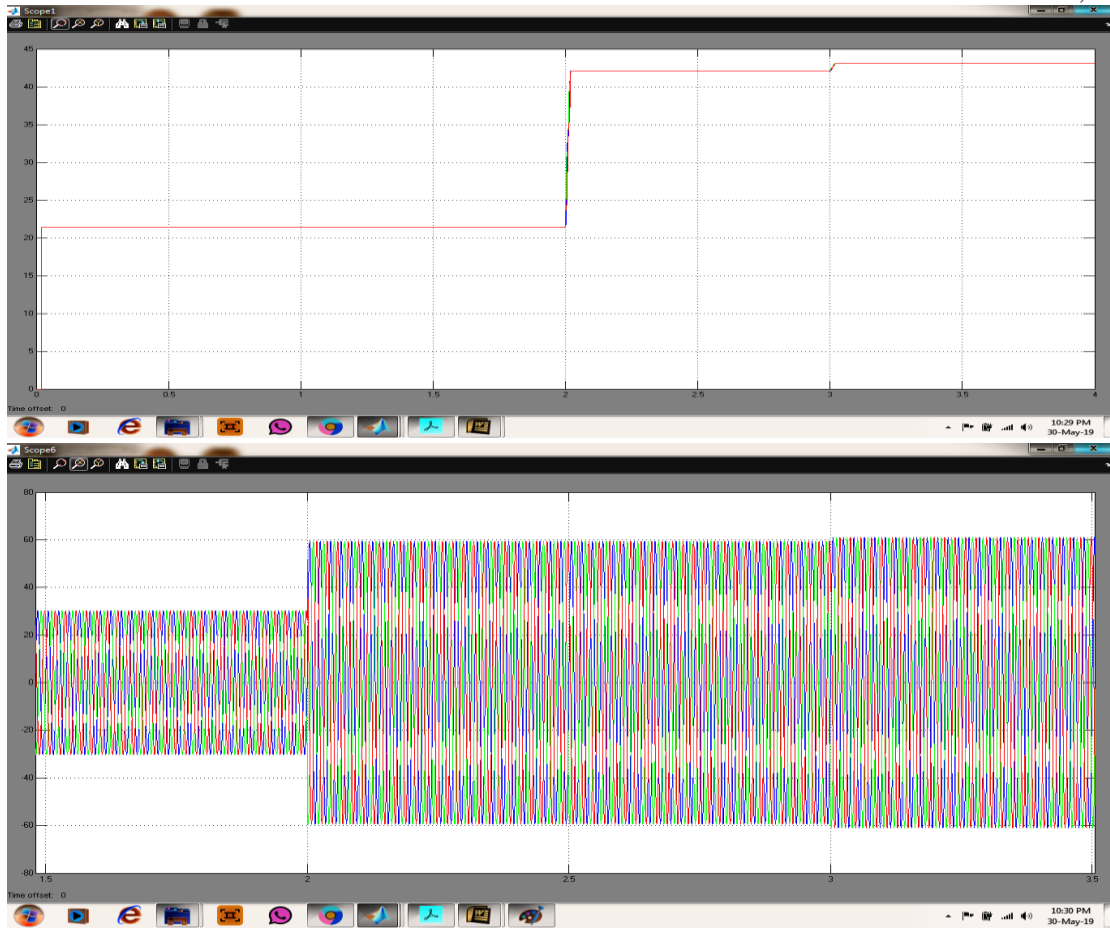
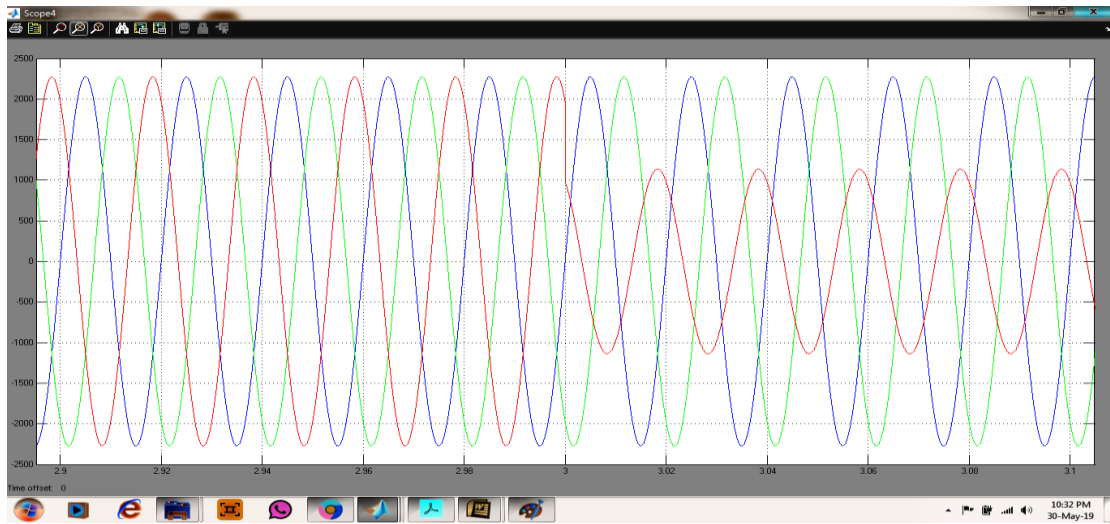

Fig. 11. Three-phase grid RMS currents and transient values by the proposed method.



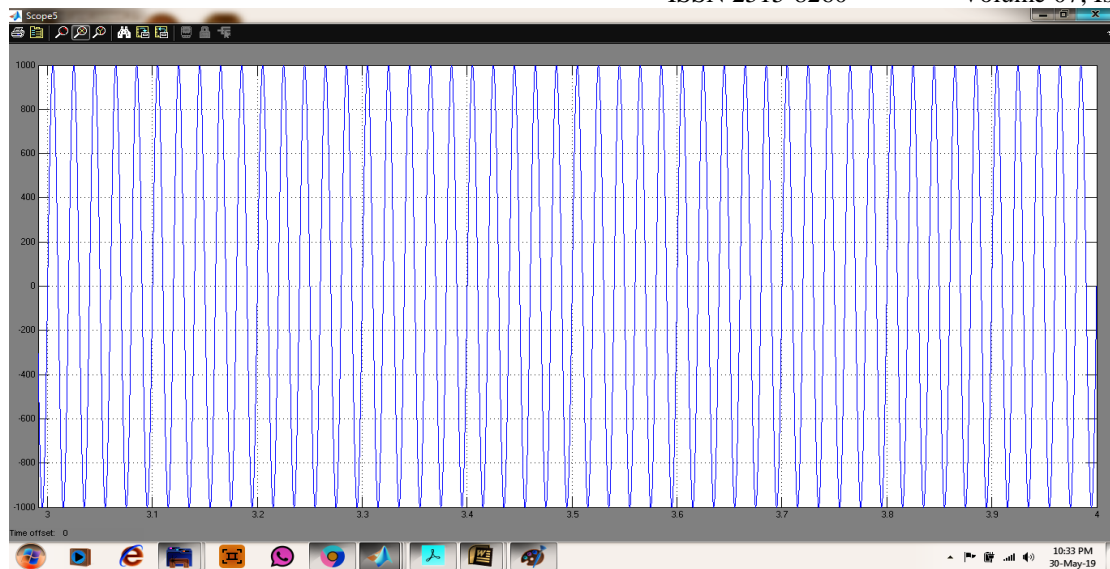

Fig. 12. Dynamic zero-sequence voltage and three-phase grid voltages by the proposed method.

Voltages of DC capacitors by cascade h-bridge converters system along utility producing currents appeared in figure 10, 11 correspondingly, it examines exactly double operation of controls by the DC voltage of capacitor currents can be balanced, the zero sequence voltages along utility voltages appeared in figure 12, this method is used interphase with phases are considered.

#### 4. CONCLUSION

A three-terminal DC/AC microgrid structure is multi power transformation stages is depicted completely along with three-stage microgrid within both DC terminals endures basically chosen for contextual analysis. So as to tackle the issues is DC voltages capacitor along three-stage network flows un even brought about by crisscrossed DC power distinct DC terminals, then improvement to controlled strategy throughout effective appropriation by zero grouping voltages infusion are created. Then that broadly checked by lattice current along cascade h-bridge voltage of capacitor adjusting controlled to be accomplished at the same time even in the extreme case with profoundly confounded DC power to, network voltage droops, or the progressions of association among AC and DC sub grids are satisfied.

#### 5. REFERENCES

- [1] P. Ch. Loh, D. Li, Y. K. Chai, and F. Blaabjerg, "Autonomous operation of hybrid microgrid with AC and DC subgrids," *IEEE Trans. Power Electron.*, vol. 28, no. 5, pp. 2214–2223, May. 2013.
- [2] P. Ch. Loh, D. Li, Y. K. Chai, and F. Blaabjerg, "Autonomous control of interlinking converter with energy storage in hybrid AC–DC microgrid," *IEEE Trans. Ind. Appl.*, vol. 49, no. 3, pp. 1374–1383, May. 2013.
- [3] Y. W. Li, D. M. Vilathgamuwa, and P. C. Loh, "Design, analysis and real-time testing of controllers for multi-bus microgrid system," *IEEE Trans. Power Electron.*, vol. 19, no. 5, pp. 1195–1204, Sep. 2004.
- [4] J. M. Guerrero, J. C. Vasquez, J. Matas, L. G. de Vicuna, and M. Castilla, "Hierarchical control of droop-controlled AC and DC microgrids—A general approach toward standardization," *IEEE Trans. Ind. Electron.*, vol. 58, no. 1, pp. 158–172, Jan. 2011.
- [5] K. T. Tan, X. Y. Peng, P. L. So, Y. C. Chu, and M. Z. Q. Chen, "Centralized control for parallel operation of distributed generation inverters in microgrids," *IEEE Trans. Smart Grid*, vol. 3, no. 4, pp. 1977–1987, Dec. 2012.
- [6] B. Wang, M. Sechilariu, and F. Locment, "Intelligent DC microgrid with smart grid communications: Control strategy consideration and design," *IEEE Trans. Smart Grid*, vol. 3, no. 4, pp. 2148–2156, Dec. 2012.

- [7] X. Liu, P. Wang, and P. C. Loh, "A Hybrid AC/DC microgrid and its coordination control," *IEEE Trans. Smart Grid*, vol. 2, no. 2, pp. 278–286, Jul. 2011.
- [8] J. He, Y. Li, J. Guerrero, F. Blaabjerg, and J. Vasquez, "An islanding microgrid power sharing approach using enhanced virtual impedance control scheme," *IEEE Trans. Power Electron.*, vol. 28, no. 11, pp. 5272–5282, Nov. 2013.
- [9] X. Lu, J. M. Guerrero, and K. Sun, "An improved droop control method for DC microgrids based on low bandwidth communication with DC bus voltage restoration and enhanced current sharing accuracy," *IEEE Trans. Power Electron.*, vol. 29, no. 4, pp. 1800–1813, Apr. 2014.
- [10] J. Rocabert, A. Luna, F. Blaabjerg, and P. Rodriguez, "Control of power converters in ac microgrids," *IEEE Trans. Power Electron.*, vol. 27, no. 11, pp. 4734–4749, Nov. 2012.
- [11] C. S. Wang, X. L. Li, L. Guo, and Y. W. Li, "A nonlinear-disturbance-observer-based DC-bus voltage control for a hybrid AC/DC microgrid," *IEEE Trans. Power Electron.*, vol. 29, no. 11, pp. 6162–6177, Nov. 2014.
- [12] K. Kurohane, T. Senjyu, A. Yona, N. Urasaki, T. Goya, and T. Funabashi, "A hybrid smart AC/DC power system," *IEEE Trans. Smart Grid*, vol. 1, no. 2, pp. 199–204, Sep. 2010.
- [13] F. Nejabatkhah, Y. W. Li, "Overview of power management strategies of hybrid AC/DC microgrid," *IEEE Trans. Power Electron.*, vol. 30, no. 12, pp. 7072–7089, Dec. 2015.
- [14] M. Li, M. M. Tong, J. E. Fletcher, and Z. Y. Dong, "A novel approach to investigate the deterioration of insulation of oils in power transformers with terahertz time-domain spectroscopy," *IEEE Trans. Dielectr. Electr. Insul.*, vol. 24, no. 2, pp. 930–938, Apr. 2017.
- [15] J. J. Dai, H. Song, G. H. Sheng, and X. C. Jiang, "Dissolved gas analysis of insulating oil for power transformer fault diagnosis with deep belief network," *IEEE Trans. Dielectr. Electr. Insul.*, vol. 24, no. 5, pp. 2828–2835, Oct. 2017.